



Product introduction

NBL-W-CO2/CO2 sensor adopts imported sensor chip, which is used to detect the concentration of CO2 in various environments, and has the characteristics of high precision and good stability. The signal transmitter adopts advanced integrated circuit modules, which can output voltage, current and other signals according to the different needs of users. The instrument is small in size, easy to install, and reliable in performance; it adopts proprietary line, which has good linearity, strong load capacity, long transmission distance and strong anti-interference ability. This product can be widely used in the detection of carbon dioxide concentration in office buildings, public places, greenhouses, production plants and other places.

Technical parameter

- Measuring range: 0~5000ppm
- Accuracy: ± (50ppm+3% reading)
- Resolution: 1ppm
- Power supply:
 - DC 12V-24V
 - other_____
- Output:
 - 4~20mA
 - RS485
- Cable length: 2.5 Meter
- Load resistance: current type: $R_L \leq 250 \Omega$
- Operating temperature: -10℃~50℃
- Relative humidity: 0~100%

product weight: 140g
 Product power consumption: 0.2W

Calculation formula

Current type (4~20mA output):

$$C = (I - 4) / 16 \times 5000$$

(C is the measured carbon dioxide concentration value (ppm), I is the output current (mA))

Wiring method

- (1) If equipped with the collector produced by our company, directly use the sensor cable to connect the sensor to the corresponding interface on the collector.
- (2) If the transmitter is purchased separately, the matching wire sequence of the transmitter is as follows:

line color	output signal		
		current type	communication type
red		V+	V+
black (green) color		V-	V-
yellow		current signal	A
blue			B

- (3) Current type output wiring method:

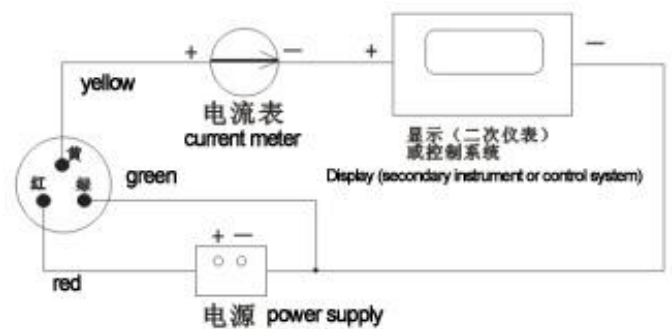

(Current output mode wiring)

Structure size

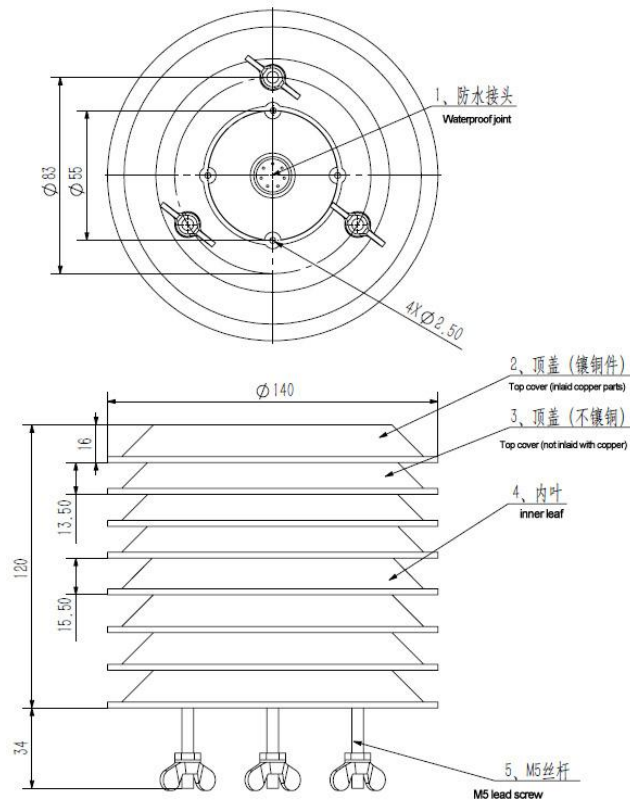

MODBUS-RTU communication protocol

一、Serial format

- Data bits 8 bits
- Stop bit 1 or 2 bits
- Check Digit None
- Baud rate 9600 The interval between two communications is at least 1000ms

二、Communication format

- 【1】 Write the device address
Send: 00 10 Adress CRC (5 bytes)
Returns: 00 10 CRC (4 bytes)
Instructions: 1. The address bit of the read/write address command must be 00.
2. Adress is 1 byte, the range is 0-255.
For example: send 00 10 01 BD C0
Return: 00 10 00 7C
- 【2】 Read the device address
Send: 00 20 CRC (4 bytes)
Returns: 00 20 Adress CRC (5 bytes)
Description: Address is 1 byte, the

range is 0-255
For example: send 00 20 00 68
Returns: 00 20 01 A9 C0

【3】 Read real-time data
Send: Address 03 00 00 00 01 XX XX
Description: As shown in the figure below:

code	Functional Definition	Remark
Address	Station number (address)	
03	function code	
00 00	starting address	
00 01	Reading points	
XX XX	CRC check code, low in the front and high in the back	

return: Address 03 02 XX XX XX XX
Description:

code	Functional Definition	Remark
Address	Station number (address)	
03	function code	
02	read unit byte	
XX XX	Data (front high and back low)	Hexadecimal
XX XX	CRC check code	

For example: send 01 03 00 00 00 01 84 0A
Return :01 03 02 01 B4 B9 A3

Note: 01 B4 converted to hexadecimal is 436, after data analysis, the actual CO2 value is 436ppm

Steps to calculate CRC code:

1. The preset 16-bit register is hexadecimal FFFF (that is, all 1s). This register is called the CRC register;
2. XOR the first 8-bit data with the lower bits of the 16-bit CRC register, and place the result in the CRC register;
3. Shift the contents of the register one bit to the right (toward the lower bit), fill the highest bit with 0, and check the shifted out bit after the right shift;
4. If the shift out bit is 0: repeat step 3 (shift right one bit again)

- If the shift-out bit is 1: XOR the CRC register with the polynomial A001 (1010 0000 0000 0001);
- Repeat steps 3 and 4 until the right shift 8 times, so that the entire 8-bit data has been processed;
 - Repeat step 2 to step 5 for the next step of 8-bit data processing;
 - The CRC register obtained at last is the CRC code;
 - When putting the CRC result into the information frame, the high and low bits are exchanged, and the low bits are first.

RS485 circuit

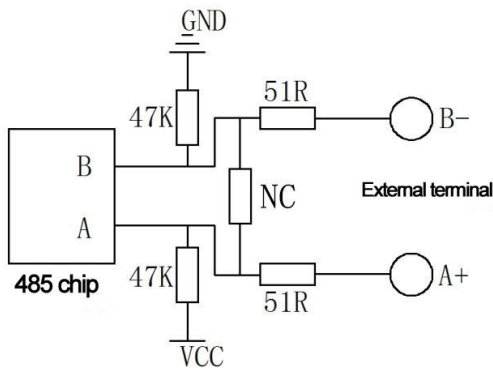

Instruction manual

Wire the sensor according to the instructions in the wiring method, then place it at the position where the carbon dioxide concentration is to be measured, turn on the power supply and the switch of the collector, and the carbon dioxide concentration at the measurement point can be obtained.

Precautions

- Please check whether the packaging is in good condition, and check whether the product model is consistent with the selection;
- Do not operate with power on, and power on after the wiring is completed and checked;
- The length of the sensor line will affect the output signal of the product. Do not arbitrarily change the components or wires that have been soldered when the product leaves the factory. If you need to change it, please contact the manufacturer;
- The sensor is a precision device, please do not disassemble it by yourself, or touch the surface of the

sensor with sharp objects or corrosive liquid, so as not to damage the product;

- Please keep the verification certificate and qualification certificate, and return it together with the product during maintenance.

troubleshooting

- During the analog output, the displayed value is obviously too large/small. Please check whether there is oil or other dirt on the sensor housing, and wipe it off with a clean rag;
- During analog output, the display device indicates that the value is 0 or not within the range. The collector may not be able to obtain information correctly due to wiring problems. Please check whether the wiring is correct and firm;
- If not for the above reasons, please contact the manufacturer.

Selection table

Numbering	Powered	output signal	illustrate
NBL-W-CO2-			Carbon dioxide sensor (transmitter)
	12V-24V		12V-24V Powered
		A1	4-20mA
		W2-	RS485
Example: NBL-W-CO2-12V-A1: Carbon dioxide sensor (transmitter) 12V power supply, 4-20mA current signal output			

Contact us

Pre-sales consultation: +8618073152920
 After-sales service: +8615367865107
 post code: 421000
 web address: <http://www.niubol.com>
 Address: Room 103, Zone D, Houhu Industrial Park, Yuelu District, Changsha City, Hunan Province, China