



Product introduction

The water level sensor uses a high-precision, high-stability diffusion silicon pressure-sensitive chip, and through a high-reliability amplifying circuit, converts the water level signal of the liquid to be measured into signals such as current and voltage, which are available for users to choose. This product can be widely used in industrial field water level measurement and control, hydrological measurement and monitoring, ships and navigation systems.

Technical Parameters

Measuring range: 0~1000mm
Accuracy: $\pm 0.5\%$ (0~+50°C)
Resolution: 0.1mm
Power supply mode: DC 12-24V
 Other
Output form: Current: 4~20mA
 Voltage: 0~5V
 RS485
 Other
Working temperature: -40°C~85°C
Relative humidity: 0-100%RH

Calculation formula

Voltage type:
 $E=V/2.5$
Among them: E - water level
V—water level channel input voltage, range 0-2500mV

Interface description

1. Voltage output wiring

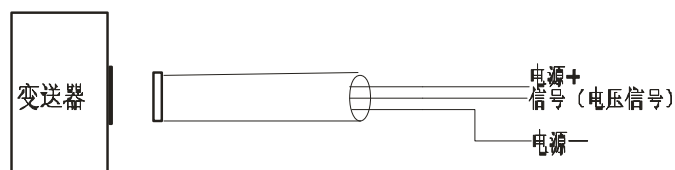

Red wire: Power+
Yellow wire: signal (voltage signal)
Green wire: Power-

2. Current mode output wiring

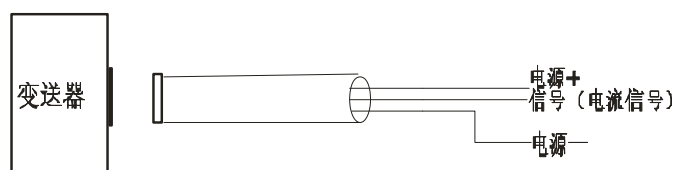

Red wire: Power+
Yellow wire: signal (current signal)
Green wire: Power-

Connection method

(1) If equipped with the weather station produced by our company, directly use the sensor cable to connect the sensor to the corresponding interface on the weather station.

(2) If the transmitter is purchased separately, the matching line sequence of the transmitter is as follows:

Line Color	Output signals		
	Voltage	Current	Communications
Red	+	+	+
Black (Green)	-	-	-
Yellow	Voltage signals	Current signals	A
Blue			B

(3) There are two output wiring methods for

transmitter voltage and current:

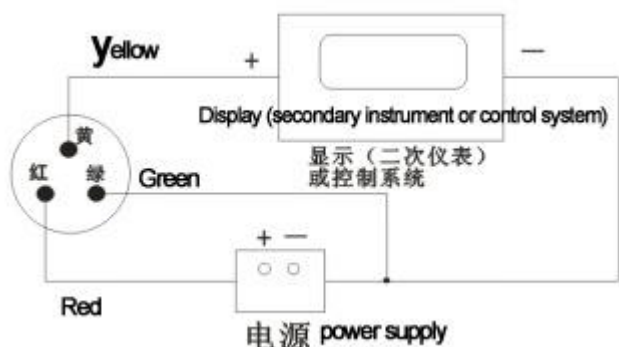

(voltage output mode wiring)

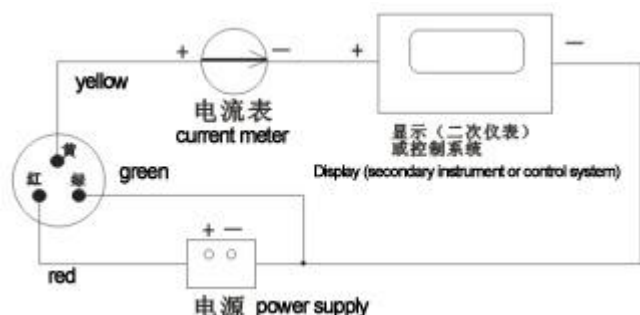

(Current output mode wiring)

Dimensions

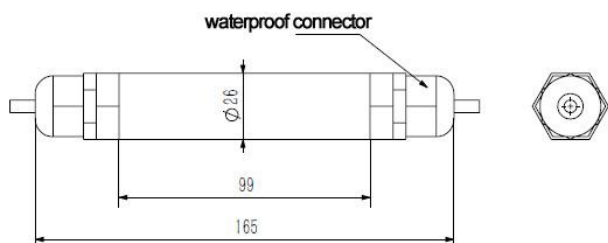

MODBUS-RTU Communication

protocol

I Serial port format

Data bits 8 bits

Stop bit 1 or 2 bits

Check Digit None

Baud rate 9600 The interval between two communications is at least 1000ms

II Communication format

【1】 Write the device address

Send: 00 10 Address CRC (5 bytes)

Returns: 00 10 CRC (4 bytes)

Instructions: 1. The address bit of the read/write address command must be 00.

2. Address is 1 byte, the range is 0-255.

For example: send 00 10 01 BD C0

return 00 10 00 7C

【2】 Read the device address

Send: 00 20 CRC (4 bytes)

Returns: 00 20 Address CRC (5 bytes)

Description: Address is 1 byte, the range is 0-255

For example: send 00 20 00 68

Return 00 20 01 A9 C0

【3】 Read real-time data

Send: Address 03 00 00 00 01 XX XX

Description: As shown in the figure below:

Code	Functional Definition	Remark
Address	Station No. (Address)	
03	Function code	
00 00	Start address	
00 01	Read points	
XX XX	CRC Check code, low front and high back	

Return: Address 03 02 XX XX XX XX

Explanation

Code	Functional Definition	Remark
Address	Station No. (Address)	
03	Function code	
02	Read unit byte	
XX XX	Data (front high and back low)	Hex
XX XX	CRC Check code	

For example:

Send 01 03 00 00 00 01 84 0A

Return 01 03 02 00 B4 B8 33

Note: 00 B4 converted to decimal is 180, after data analysis, with one decimal point, it needs to be divided by ten, the actual water

level is 18.0 mm

Steps to calculate CRC code:

1. The preset 16-bit register is hexadecimal FFFF (that is, all 1s). Call this register the CRC register;
 2. XOR the first 8-bit data with the lower bits of the 16-bit CRC register, and place the result in the CRC register;
 3. Shift the contents of the register one bit to the right (toward the lower bit), fill the highest bit with 0, and check the shifted out bit after the right shift;
 4. If the shift out bit is 0: repeat step 3 (shift right one bit again)
- If the shift-out bit is 1: XOR the CRC register with the polynomial A001 (1010 0000 0000 0001);
5. Repeat steps 3 and 4 until the right shift is performed 8 times, so that the entire 8-bit data is processed;
 6. Repeat steps 2 to 5 to process the next 8-bit data;
 7. The final CRC register is the CRC code;
 8. When the CRC result is put into the information frame, the high and low bits are exchanged, and the low bits are first.

RS485 ircuit

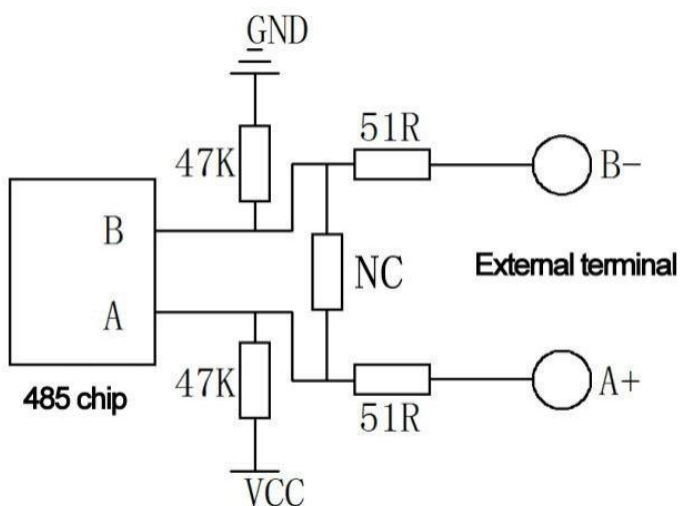

Instructions for use

1. Whether the water level at the installation site will exceed the range of this product;

2. Whether the measured liquid will block the pressure-inducing hole of the loosener, in still water, such as installation in a pool, generally put the measuring part directly into the water for measurement, but pay attention to the place away from the inlet and outlet of the pump. Select the sensor bracket and lock nut accessories provided by the product to fix the water level sensor in the required installation position.

Notice

1. Please check whether the packaging is in good condition, and check whether the product model is consistent with the selection;
2. Do not connect with live power. After the wiring is completed and checked, the power can be turned on;
3. Do not arbitrarily change the components or wires that have been welded when the product leaves the factory;
4. The sensor is a precision device, please do not disassemble it by yourself, or touch the surface of the sensor with sharp objects or corrosive liquid, so as not to damage the product;
5. Please keep the verification certificate and qualification certificate, and return it together with the product during maintenance.

Instrument maintenance

1. Requirements for water use of the water level device: water that represents the local natural water body (river, river, lake) should be used as much as possible. In areas where it is difficult to obtain natural water, drinking water (well water, tap water) can also be used; the water in the device To keep clean, there is no floating objects on the water surface, no small insects and suspended dirt in the water, no moss, no significant change in water color; generally

change the water once a month. The water level bucket should be cleaned when the water level gauge is changed, and the temperature of the replaced water should be close to the temperature of the original water;

2. Stop observations in areas with a long freezing period in winter, and use a small water level gauge to observe the water level on the ice surface throughout the freezing period. Drain the water in the large water level gauge to avoid freezing;

3. Before and after the flood season (for long-term stable frozen areas, before starting to use and after stopping use), check the leakage of the water level device once a year; if any problems are found, they should be dealt with;

4. Regularly check the installation of the water level gauge. If it is found that the height is inaccurate or not level, it should be corrected in time;

5. The water surface in the water ring should be close to the water surface in the water level bucket.

Contact Us

Contact: +8615367865107/+8618073152920

Zip code: 421000

Email: sales@niubol.com

Website: <http://www.niubol.com>

Address: Room 103, Area D, Houhu Industrial Park,
Yuelu District, Changsha City, Hunan Province, China