



**Product introduction**

Rain sensor (transmitter) is suitable for meteorological stations (stations), hydrological stations, agriculture, forestry, national defense and other relevant departments, used to remotely measure liquid precipitation, precipitation intensity, precipitation start and end time. This instrument organizes production, assembly and verification in strict accordance with the SL61-2003 hydrological automatic forecasting system specification, GB11831-89 hydrological forecasting device telemetry rain gauge, and GB11832-89 national standard for tipping bucket rain gauge. It can be used for automatic hydrological monitoring and reporting systems and automatic field monitoring and reporting stations for the purposes of flood control, water supply scheduling, and hydrological management of power stations and reservoirs.

**Technical Parameters**

Water bearing diameter:  $\Phi 200 \pm 0.6\text{mm}$   
 Measuring range: 0-4mm/min (precipitation intensity)  
 Resolution: 0.2mm (6.28ml)  
 Accuracy:  $\pm 4\%$  (indoor static test, rain intensity is 2mm/min)  
 Power supply mode:  DC 5V  DC 12V-24V  
 Output form:  Switch signal: Reed switch on and off

- Voltage 0~2.5V
- Voltage 0~5V
- RS485
- Other

Instrument cable length:  Standard: 5 meters  
 Working temperature: 0~50°C  
 Storage temperature: -40°C~80°C  
 Product weight: the bucket weighs 1700 g, and the total weight is 3300 g

**Connection method**

- (1) If equipped with the weather station produced by our company, directly use the sensor cable to connect the sensor to the corresponding interface on the weather station.
- (2) If the sensor is purchased separately, since the sensor outputs a set of switch signals, the cable connector does not matter whether it is positive or negative. Connect the sensor to the circuit as shown.

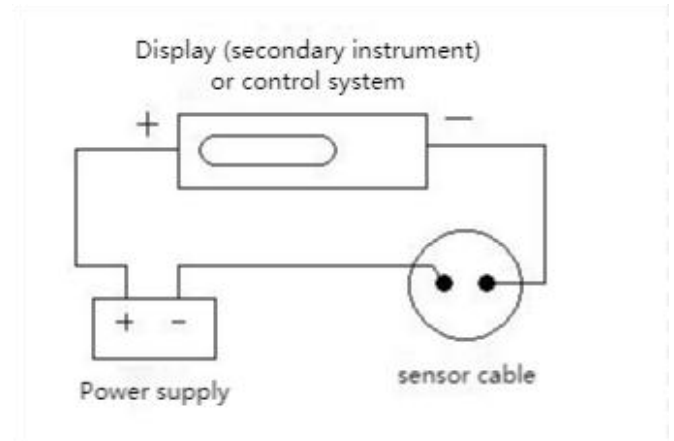

- (1) If the sensor outputs other signals, the conventional sensor line sequence and function correspondence are as follows:

Line color	output signal			
	Pulse	Current	Voltage	Communication
Red	+	+	+	+
Black (Green)	Pulse signal	-	-	-
Yellow		Current signal	Voltage signal	A
Blue				B

**Structural dimensions**

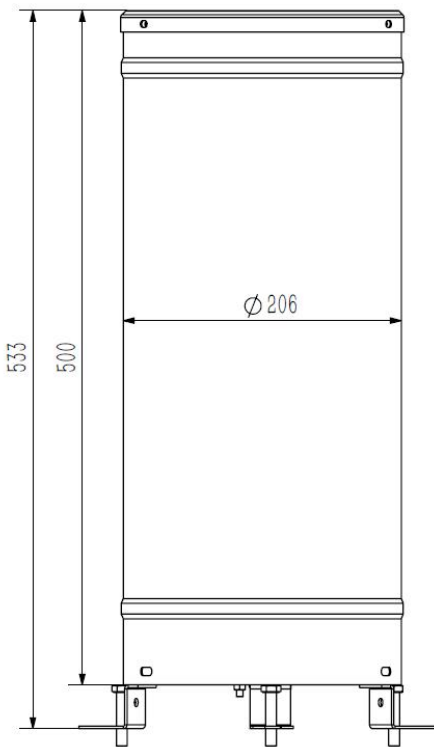
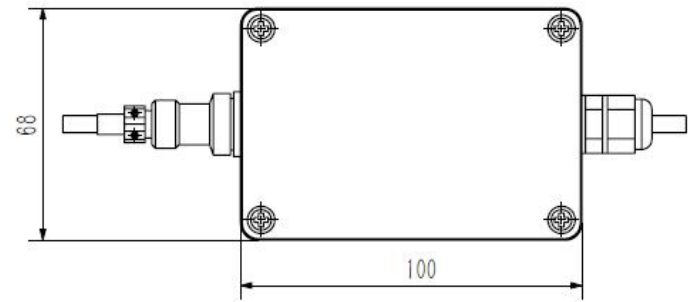
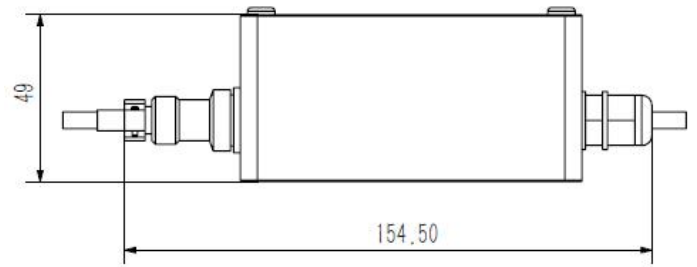
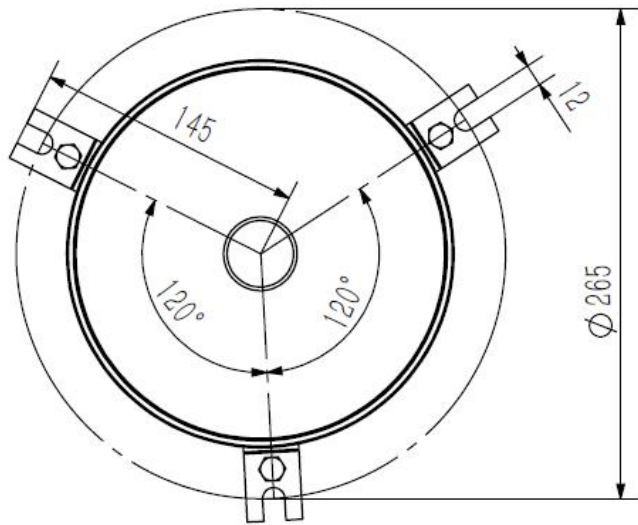

**Transmitter Dimensions**

**MODBUS-RTU Communication protocol**

I Serial port format

Data bits 8 bits

Stop bit 1 or 2 bits

Check Digit None

Baud rate 9600 The interval between two communications is at least 1000ms

II Communication format

[1] Write device address

Send: 00 10 Address CRC (5 bytes)

Returns: 00 10 CRC (4 bytes)

Instructions: 1. The address bit of the read/write address command must be 00.

2. Address is 1 byte, the range is 0-255.

For example: send 00 10 01 BD C0

return 00 10 00 7C

[2] Read device address

Send: 00 20 CRC (4 bytes)

Returns: 00 20 Address CRC (5 bytes)

Description: Address is 1 byte, the range is 0-255

For example: send 00 20 00 68

Return 00 20 01 A9 C0

[3] Read real-time data

Send: Address 03 00 00 00 01 XX XX

Description: As shown in the figure below:

**NBL-W-RS/Rain sensor**  
 Changsha Zoko Link Technology Co., Ltd.

CODE	Functional Definition	Remark
Address	Station number (address)	
03	Function code	
00 00	Start address	
00 01	Read points	
XX XX	CRC Check code, low front and high back	

Return: Address 03 02 XX XX XX XX

Description:

CODE	Functional Definition	Remark
Address	Station number (address)	
03	Function code	
02	Read unit bytes	
XX XX	Date ( low front and high back )	Hex
XX XX	CRC Check code	

For example: send 01 03 00 00 00 01 84 0A

Back 01 03 02 00 1A 39 8F

**Note: 00 1A converted to hexadecimal is 26, after data analysis, with one decimal point needs to be divided by ten, the actual rainfall value is 2.6mm**  
**Steps to calculate CRC code:**

1. The preset 16-bit register is hexadecimal FFFF (that is, all 1s). Call this register the CRC register;
2. XOR the first 8-bit data with the lower bits of the 16-bit CRC register, and place the result in the CRC register;
3. Shift the contents of the register one bit to the right (toward the lower bit), fill the highest bit with 0, and check the shifted out bit after the right shift;
4. If the shift out bit is 0: repeat step 3 (shift right one bit again)  
 If the shift-out bit is 1: XOR the CRC register with the polynomial A001 (1010 0000 0000 0001);
5. Repeat steps 3 and 4 until the right shift is performed 8 times, so that the entire 8-bit data is processed;
6. Repeat steps 2 to 5 to process the next 8-bit data;
7. The final CRC register is the CRC code;
8. When the CRC result is put into the information

frame, the high and low bits are exchanged, and the low bits are first.

### RS485 Circuit

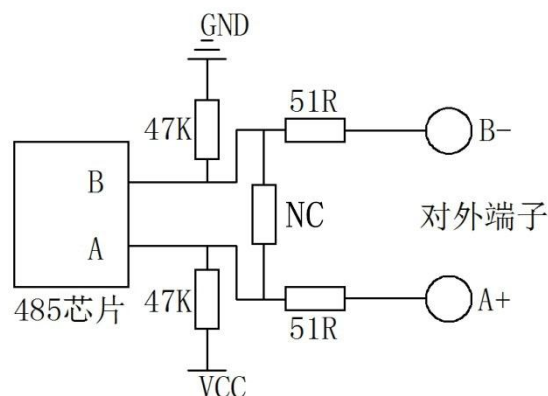

### Installation

1. The installation position of the sensor can be selected on the ground, self-made large cylinder, iron column flange or roof according to actual requirements;
2. Adjust the three leveling screws on the chassis to make the level bubble indicate level (the bubble stays in the center of the circle), and then slowly tighten the three M8 × 80 fixing expansion screws; if the level bubble changes, it needs to be readjusted ;
3. As shown in the figure above, assemble and fix the sensor;
4. After fixing, open the rain gauge bucket, cut off the nylon tie on the funnel, slowly pour clean water into the rain gauge sensor, observe the turning process of the tipping bucket, and check whether the data is received on the collecting instrument. Finally inject quantitative water (60-70mm), if the data displayed by the collecting instrument is consistent with the injected water volume, it means that the instrument is normal, otherwise it must be repaired and adjusted;
- 1、 5. Please avoid disassembling the sensor during installation.

### Notice

1. Please check whether the packaging is in good condition, and check whether the product model is consistent with the selection;
2. Do not connect with live power. After the wiring is

## NBL-W-RS/Rain sensor

*Changsha Zoko Link Technology Co., Ltd.*

- completed and checked, the power can be turned on;
3. The length of the sensor line will affect the output signal of the product. Do not arbitrarily change the components or wires that have been soldered when the product leaves the factory. If you need to change it, please contact the manufacturer;
  4. The sensor should be checked regularly to remove dust, mud sand, leaves and insects, so as not to block the water flow channel of the upper cylinder (funnel), and the cylindrical filter can be removed and washed with clean water;
  5. If there is dirt on the inner wall of the tipping bucket, it can be washed with water or alcohol or detergent solution. It is strictly forbidden to wipe it with fingers or other objects to avoid oil stains or scratches on the inner wall of the tipping bucket;
  6. During the freezing period in winter, the instrument should be stopped and it can be taken back indoors;
  7. Please keep the verification certificate and qualification certificate, and return it together with the product during maintenance.

### Trouble Clearing

1. The display meter has no indication value;
2. The acquisition instrument may not be able to obtain information correctly due to wiring problems. Please check whether the wiring is correct and firm;
3. Check whether the inner tipping tie has been cut.
4. The value indicated by the display device is obviously inconsistent with the actual situation:
5. Please empty the water in the bucket, and then re-fill the bucket with quantitative water (60-70mm), and clean the inner wall of the tipping bucket;
6. If not for the above reasons, please contact the manufacturer.

### Selection table

No.	Power supply	output signal	explanation
NBL-W-RS			Rain sensor (transmitter)
	12V-24V		
		M	switch signal output
		V	0-2.5V
		V	0-5V
		W2	RS485
		X	Other
For example: NBL-W-RS-5V-M: Rain sensor. 5V power supply, switch signal output			

### Contact us

Pre-sales consultation:+86 18073152920

After-sales service: +8615367865107

Postcode: 421000

Website: <http://www.niubol.com>

Address: Room 103, Zone D, Houhu Industrial Park,

Yuelu District, Changsha City, Hunan Province,China