

NBL-CLI-206A Online Chlorine Ion Sensor

User Manual



Changsha Zoko Link Technology Co., Ltd

www.niubol.com

Tel: +86 15367865107

Email: sales@niubol.com

Add: Room 102, District D, Houhu Industrial Park, Yuelu District, Changsha City, Hunan Province, China

User Notes

- Please read the instruction carefully before using and save it for reference.
- Please follow the instructions and precautions.
- When receiving the instrument, please open the packaging carefully, inspect equipment's damage level in case of transportation, if you found spoiled equipment, please immediately notify the manufacturer and distributor, and retain the packaging, in order to send back to processing.
- When the instrument is in trouble, please don't repair it by yourself, please directly contact the maintenance department of the manufacturer.

Content

User Notes	2
I 、 Application environment description	4
II 、 Technical performance and specifications	4
1. Technical parameter	4
2. Dimensional drawing	5
III、 Electrical connection	5
1. Installation	5
2. Electrical connection	6
IV、 Maintenance	6
1. Detection and maintenance of sensors	6
2. Calibration of the sensor	6
V 、 Quality and service	7
1. Quality assurance	6
2. Spare parts	7
3. After-sales service commitment	7
Appendix data communication	7

I 、 Application Environment description

The NBL-CLI-206A integrated online chloride ion sensor uses an ion-selective electrode with a solid membrane for testing free chlorine ions in water, making it fast, simple, accurate and economical. In this manual, the technical parameters, communication protocol, operation and maintenance of the chloride ion sensor are introduced in detail.

- Signal output: RS-485 bus, Modbus/RTU protocol, easy to connect to PLC, DCS, industrial control computer, general controller, paperless recording instrument or touch screen and other third-party devices.
- The patented chloride ion electrode, with an internal reference fluid at a pressure of at least 100KPa (1Bar), slowly seeps out of the microporous salt bridge. The reference system is very stable and the electrode life is longer than that of ordinary industrial electrodes.
- Easy to install: 3/4-inch NPT threads for submerged installation or installation in piping and tanks.
- IP68 protection grade.

II 、 Technical performance and specifications

1. Technical parameters

Model	NBL-CLI-206A	
Measuring range and Resolution	0~3500mg/L	0.1mg/L
	0~35000mg/L	1mg/L
Precision	±5%, ±0.3°C	
Working temperature	-5~65°C	
Working pressure	<0.2MPa	
pH range of the medium	2~12pH	
Temperature compensation	Automatic temperature compensation (Pt1000)	
Power supply	12~24VDC	
Signal output	RS-485 bus, Modbus/RTU protocol	
Material	POM	
Mounting method	Immersion mounting, 3/4 NPT thread	
Cable length	5 meters, other lengths can be customized	
Calibration	Two-point calibration	
Power consumption	0.2W@12V	
Protection grade	IP68	

2. Dimensional drawing

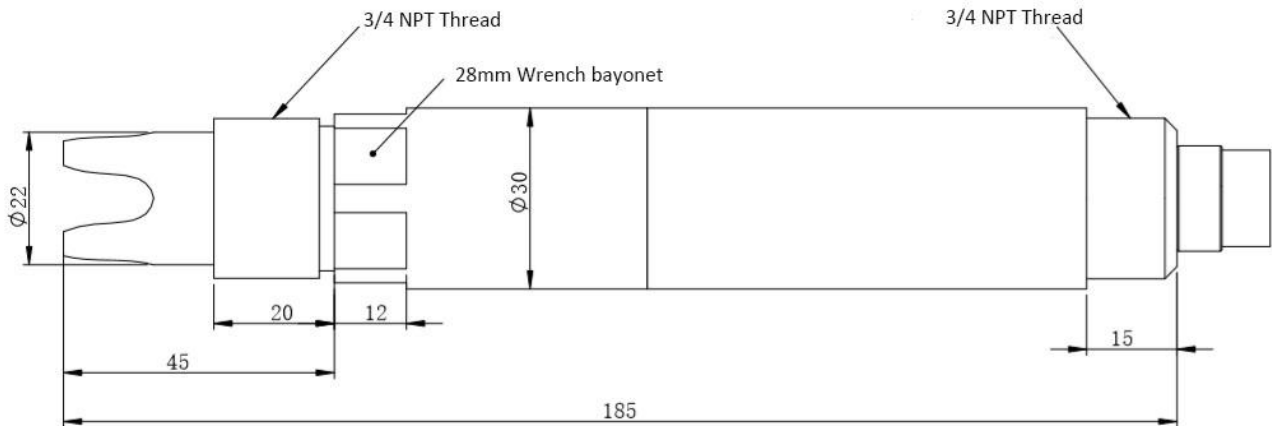

III、Electrical connection

1. Installation

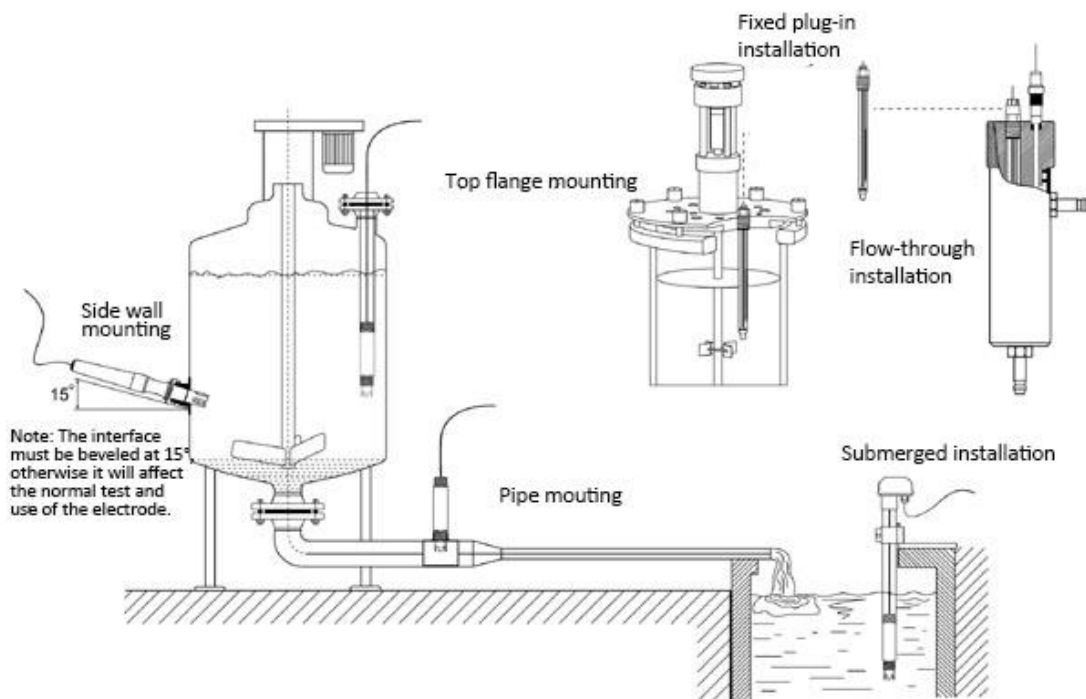

Note: When the sensor is installed, it cannot be installed upside down or horizontally, and it must be installed at an angle of at least 15 degrees.

2. Electrical connection

- a) Red wire-power cord (12~24VDC)
- b) Black wire-ground wire (GND)
- c) Blue Line-485A
- d) White Line-485B

After the wiring is completed, it should be carefully checked to avoid the wrong connection before the power is turned on.

Cable specification: Considering that the cable is immersed in water (including sea water) or exposed to air for a long time, the cable has a certain corrosion resistance. The Φ 6 mm, joint of cable outer diameter needs waterproof treatment.

IV、 Maintenance

1. Using and maintenance

- Remove the protective cap from the electrode head. Note: Do not touch the sensitive part of the electrode membrane head with your finger.
- The electrode was placed on the electrode bracket, and the front end of the electrode was immersed in deionized water for 10 minutes, and then immersed in diluted chloride ion solution for 2 hours.
- To keep the electrode dry before use, the sensor element of the electrode should be tucked into a protective bottle. The electrodes should be immersed in tap water for 24 hours prior to testing. If stored overnight or longer, the electrode head is cleaned with deionized water and dried before being placed in the original package.
- Check whether the terminal is dry. If it is stained, wipe it with anhydrous alcohol and use it after bopping. Long-term immersion in distilled water or protein solutions should be avoided and contact with silicone grease should be avoided. If the electrode is used for a long time and the measurement error occurs, it shall be calibrated with the instrument.

If the electrode cannot be calibrated and measured after the above maintenance, the electrode has failed. Please replace the electrode.

Interference ion: sulfur ion, iodide ion, bromine ion and so on.

2. Calibration of the sensor

Note: The sensor has been calibrated before leaving the factory. It is not appropriate to calibrate at will unless the measurement error is exceeded.

a) Zero calibration

Put the sensor into a vial containing standard zero point solution, wait for 5 minutes, and see if the displayed value is within the error range after the value stabilizes. If not, zero point calibration is required. Refer to the appendix for calibration instructions.

b) Slope calibration

Put the sensor into a vial with standard slope solution, wait for 5 minutes, and see if the displayed value is within the error range after the value stabilizes. If not, slope calibration is required. Refer to the appendix for calibration instructions.

V、Quality and service

1. Quality assurance

- The quality inspection department has standardized inspection rules, advanced and perfect testing equipment and means, and strictly according to the rules of inspection, a 72 hours aging test, stability test, do not let a unqualified product leave the factory.

- The consignee shall refund directly the product batches with a failure rate of 2%, and all expenses incurred shall be borne by the supplier. Consider the standard reference to the product description provided by the supplier.

- Ensure the quantity of goods and the speed of shipment.

2. Spare parts

This product includes

- Sensor 1
- 1 copy of the manual
- 1 certificate of qualification
- Select 100mg/L and 1000mg/L calibration fluids 100mL each or 1000mg/L and 10000mg/L standard fluids 100mL each, depending on the range

3. After-sales service commitment

The company provides local after-sales service within one year from the date of sale, but does not include damage caused by improper use. If repair or adjustment is required, please return it, but the shipping cost must be concealed. Damaged on the way, the company will repair the damage of the instrument for free.

Appendix data communication

1. Data format

The default data format for Modbus communication is 9600, n,8,1 (baud rate 9600 bps,1 start bit,8 data bits, no check,1 stop bit). The baud rate and other parameters can be customized.

2. Information frame format

a) Read data instruction frame

06	03	xx xx	xx xx	xx xx
Address	FC	register address	Number of registers	CRC check code (low bytes in front)

b) read data response frame

06	03	xx	xx.....xx	xx xx
Address	FC	Number of bytes	Response data	CRC check code (low bytes in front)

c) Write data instruction frame

06	06	xx xx	xx xx	xx xx
Address	FC	register address	read-in data	CRC check code (low bytes in front)

d) Write data reply frame (same as data instruction frame)

06	06	xx xx	xx xx	xx xx
Address	FC	register address	read-in data	CRC check code (low bytes in front)

3. Register address

Register address	Name	Explain	Number of registers	Access mode
40001 (0x0000)	Chlorine ion measurements+temperature	4 double-byte integers are the measured value of chloride ion, the measured decimal value, the temperature decimal value and the temperature decimal value.	4 (8 bytes)	Read
44097 (0x1000)	Zero calibration	When the range is 0-3500mg/L, it shall be calibrated in 100mg/L standard liquid, and the data shall be written as the value of standard liquid concentration x10.The data read out is mV value x100 corresponding to the zero calibration value.When the range is 0-35000mg/L, the written data shall be calibrated in 1000mg/L standard solution as the actual value of standard solution;The data read out is mV value x100 corresponding to the zero calibration value.	1 (2 bytes)	Write/Read
44101 (0x1004)	Slope calibration	When the range is 0-3500mg/L, calibrate in 1000mg/L standard solution and write data as the actual value of standard solution x10;The data read out is mV x100 corresponding to the slope calibration value.When the range is 0-35000mg/l, it shall be calibrated in 10000mg/ l standard liquid. The written data shall be the actual concentration value of standard liquid and the read data shall be the actual slope value (mv) x100.	1 (2 bytes)	Write/Read

44113 (0x1010)	Temperature calibration	Calibrate in solution and write data as actual temperature x10;The readout data is the temperature calibration offset x10.	1 (2 bytes)	Write/Read
48195 (0x2002)	Device address	Default address is 6, data range is 1-127.	1 (2 bytes)	Write/Read
48225 (0x2020)	factory reset	Restore calibration values to factory settings, write data to 0.	1 (2 bytes)	Write

4. Command example

a) Read data instruction:

Function: To obtain the value and temperature of chlorine ion measured by the sensor;The unit of chloride ion is mg/L;The unit of temperature is °C.

Request frame: 06 03 00 00 00 04 45 BE

Response frame: 06 03 08 00 55 00 00 01 18 00 01 CA 9D

Example of reading:

Chloride ion value	Temperature value
00 55 00 00	01 18 00 01

For example: chloride ion value: 00 55 means hexadecimal reading chloride ion value, 00 00 means chloride ion value with zero decimal, converted to decimal value is 85.

Temperature value: 01 18 represents the hexadecimal reading temperature value, 00 01 represents the temperature value with a decimal value, converted to decimal value is 28.0.

b) Calibration instructions:

- Zero calibration

Function:Set the calibration value of chlorine ion zero of the sensor.Calibration in a standard liquid of 100mg/L, as shown below:

Request frame: 06 06 10 00 03 E8 8C 03

Response frame: 06 06 10 00 03 E8 8C 03

Calibration in 1000mg/L standard fluid, as shown below:

Request frame: 06 06 10 00 03 E8 8C 03

Response frame:06 06 10 00 03 E8 8C 03

- Slope calibration

Function: Set the calibration value of chlorine ion slope of the sensor.Calibration in 1000mg/L standard fluid, as shown below:

Request frame: 06 06 10 04 27 10 D7 40

Response frame: 06 06 10 04 27 10 D7 40

Calibration in a standard liquid of 10000mg/L, as shown below:

Request frame: 06 06 10 04 27 10 D7 40

Response frame:06 06 10 04 27 10 D7 40

- c) Set the device ID address:
 Role: set the MODBUS device address of the electrode;
 Change the device address 06 to 01. The example is as follows
 Request frame: 06 06 20 02 00 01 E3 BD
 Response frame:06 06 20 02 00 01 E3 BD

5. Error response

If the sensor does not execute the upper computer command correctly, the following format information is returned:

Definition	Address	Function code	Code	CRC verification
Data	ADDR	COM+80H	xx	CRC 16
Number of bytes	1	1	1	2

- a) CODE: 01 – Functional code error
 03–Data error
- b) COM: Received function code