

NBL-DDM-206-S Online Salinity Sensor

User Manual



Changsha Zoko Link Technology Co., Ltd.

Tel:+8615367865107

E-mail: sales@niubol.com

Website: www.niubol.com

Address: Room 102, District D, Houhu Industrial Park, Yuelu District, Changsha City,

Hunan Province, China

User Notes

- Please read this manual carefully before use and save it for reference.
- Please follow the operating procedures and precautions in this manual.
- When receiving the instrument, please carefully open the package and check whether the instrument and accessories are damaged due to shipping. If any damage is found, please inform the manufacturer and distributor immediately, and keep the package for return.
- When the instrument fails, do not repair it yourself. Please contact the maintenance department of the manufacturer directly.

Content

User Notes	1
I 、 Application environment	4
II 、 Technical performance and specifications	4
1. Technical parameters	4
2. Dimensional drawing	5
III 、 Installation and electrical connection	5
1. Installation	5
2. Electrical connection	5
IV 、 Maintenance and maintenance	6
1. Use and maintenance	6
2. Calibration	6
V 、 Quality and service	6
1. Quality assurance	6
2. Accessories and spare parts	7
3. After-sales service commitment	7
Appendix data communication	8

I 、 Application environment

- Sea water / heavy salt water / various water supply / industrial water treatment.
- Signal output: RS-485 (Modbus/RTU protocol).
- Convenient connection to third-party equipment such as PLC, DCS, industrial control computer, general controller, paperless recording instrument or touch screen.
- Immersion installation with 3/4 NPT pipe thread for easy submersible installation or installation in pipes and tanks.
- IP68 protection grade.

II 、 Technical performance and specifications

1. Technical parameters

Model	NBL-DDM-206-S
Measuring range	0~70.0PSU
Resolution	0.1PSU
Precision	±1.5%F.S., ±0.5°C
Working temperature	0~65°C
Working pressure	<0.6MPa
Power supply	12~24VDC
Signal output	RS-485(Modbus/RTU)
Wetted material	ABS(Default) / POM
Mounting method	Immersion mounting, 3/4 NPT thread
Cable length	5 meters, other lengths can be customized
Temperature compensation	Auto temperature compensation (Pt1000)
Calibration	Two-point calibration
Power consumption	0.2W@12V
Protection grade	IP68

2. Dimensional drawing

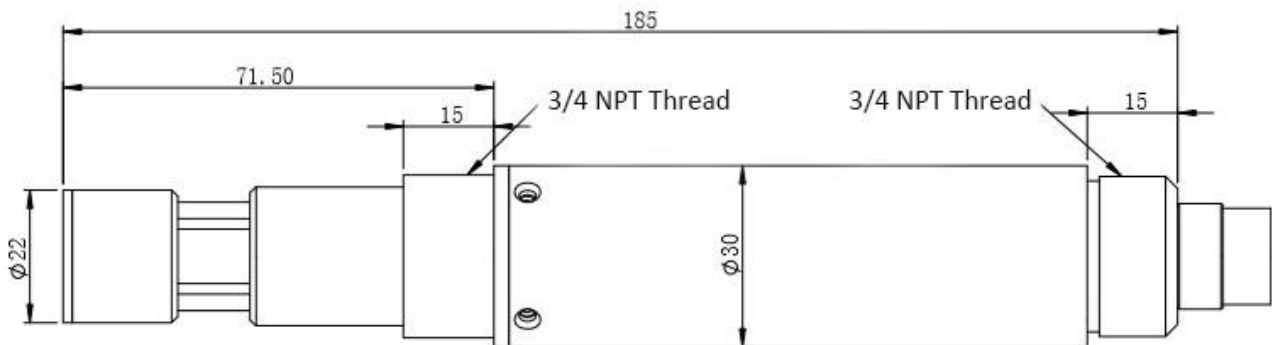

III、 Installation and electrical connection

1. Installation

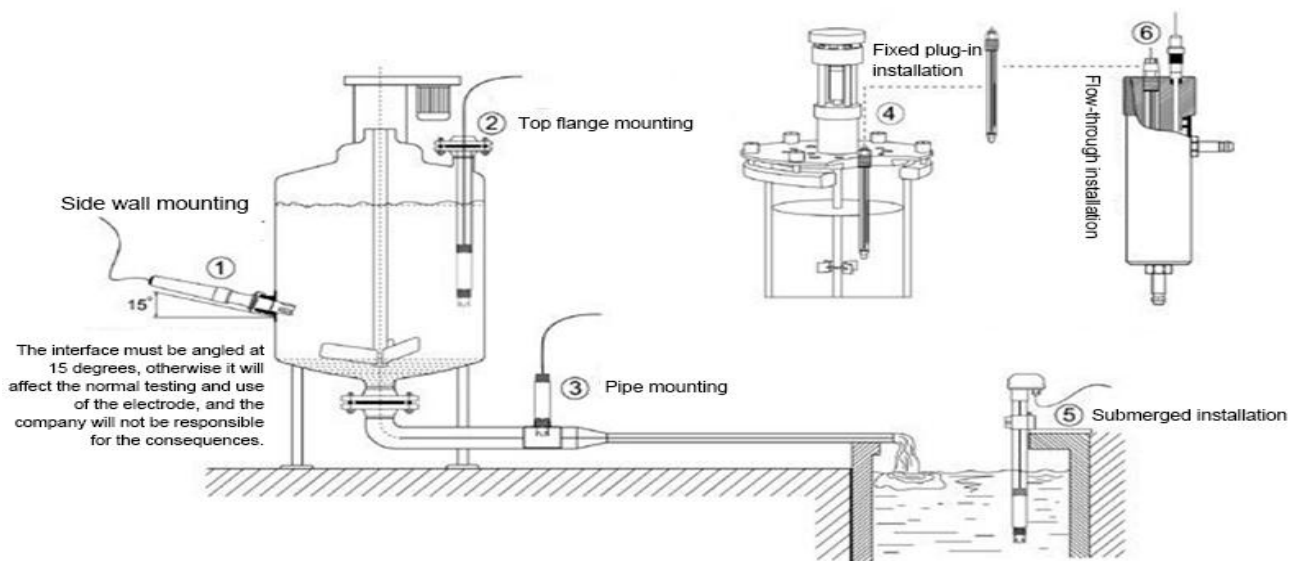

Note: At least 2 cm from the bottom and side walls of the container during installing and testing.

2. Electrical connection

- a) Red line - power cord (12 ~ 24V)
- b) Black line - ground (GND)
- c) Blue line - 485A
- d) white line - 485B

After wiring is completed, it should be carefully checked to avoid incorrect connections before

powering up.

Cable specification: Considering that the cable is immersed in water (including sea water) for a long time or exposed to the air, the cable has certain corrosion resistance. The outer diameter of the cable is $\Phi 6$ mm and all interfaces are waterproof.

IV、 Maintenance

1. Use and maintenance

Conventional electrodes require periodic cleaning and calibration, and the maintenance cycle is determined by the customer based on his or her own operating conditions. Cleaning method for conventional electrode: Remove the attached material with a soft brush (be careful to avoid scratching the surface of the electrode), then rinse with distilled water, and then perform calibration.

Electrode cleaning method:

- The inductive salinity electrode is basically maintenance-free, and its normal operation will not be affected by pollution or slight scaling of the shell.
- If it needs clean, use a soft brush or sandpaper to remove attachments, and then clean with distilled water, calibration after operation.
- Because the inductive electrode often works in the environment which is easy to scale or dirty, the cleaning strength can be increased appropriately. Slight scratches on the electrode surface will not affect the normal operation of the electrode, but it is necessary to avoid penetrating the electrode shell.

2. Calibration

a) Zero calibration

Rinse the sensor with distilled water and blot the liquid with filter paper. Place the sensor on the power supply and place it in the air for about 3 minutes. After the value is stable, perform zero calibration.

b) Slope calibration

Place the electrode vertically in a standard solution (20% full scale - full scale). Note that the electrode is at least 2 cm from the bottom and side walls of the vessel for slope calibration. The calibration instructions are detailed in the appendix.

V、 Quality and service

1. Quality assurance

- The quality inspection department has standardized inspection procedures, advanced and perfect testing equipment and means, and strictly in accordance with the regulations, to do

72-hour aging test and stability test on the product, and not to allow one unqualified product to leave the factory.

- The receiving party directly returns the product batch with a failure rate of 2%, and all the costs incurred are borne by the supplier. The reference standard refers to the product description provided by the supplier.
- Guarantee the quantity of goods and the speed of shipment.

2. Accessories and spare parts

This product includes:

- 1 sensor
- 1 copy of the instruction manual
- 1 certificate
- Calibration solution (optional)

3. After-sales service commitment

The company provides local after-sales service within one year from the date of sale, but does not include damage caused by improper use. If repair or adjustment is required, please return it, but the shipping cost must be concealed. Damaged on the way, the company will repair the damage of the instrument for free.

Appendix Data Communication

1. Data format

The default data format for Modbus communication is: 9600, n, 8, 1 (baud rate 9600bps, 1 start bit, 8 data bits, no parity, 1 stop bit).

Parameters such as baud rate can be customized.

2. Information frame format

a) Read data instruction frame

```

08          03          xx xx          xx  xx          xx  xx
Address  Function code  Register address  Number of registers  CRC check code (low byte first)
  
```

b) Read data response frame

```

08          03          xx          xx.....xx          xx  xx
Address  Function code  Bytes  Answer data          CRC check code (low byte first)
  
```

c) Write data instruction frame

```

08          06          xx  xx          xx  xx          xx  xx
Address  Function code  Register address  Write data          CRC check code(low byte first)
  
```

d) Write data response frame (same data command frame)

```

08          06          xx  xx          xx  xx          xx  xx
Address  Function code  Register address  Write data          CRC check code (low byte first)
  
```

3. Register address

Register address	Name	Instruction	Number of registers	Access method
40001 (0x0000)	Measured value + temperature	4 double-byte integers, which are the measured value, the measured number of decimal places, the temperature value, and the decimal value of the temperature value.	4 (8 bytes)	Read
44097 (0x1000)	Zero calibration	Calibrate in the air, the read data is 0.	1 (2 bytes)	Write

44101 (0x1004)	Slope calibration	Calibrated in a known standard solution (20% full scale - full scale), the read value is actual value of standard solution *10	1 (2 bytes)	Write
44103 (0x1006)	Zero calibration value	The data is read out as a zero offset.	1 (2 bytes)	Read
44105 (0x1008)	Slope calibration value	The read data is the slope value x 1000.	1 (2 bytes)	Read
44113 (0x1010)	Temperature value	Calibrated in solution, the written data is the actual temperature value x 10; the read data is the temperature calibration offset x 10 .	1 (2 bytes)	Write/Read
48195 (0x2002)	Device address	The default is 8, writing data range 1-255.	1 (2 bytes)	Write/Read
48225 (0x2020)	factory reset	The calibration value is restored to the default value and the write data is 0. Note: The sensor needs to be calibrated again after resetting.	1 (2 bytes)	Write

4. Command example

a) Start measurement instructions

Function: Obtain the conductivity value and temperature of the measuring probe; the unit of temperature is Celsius, and the value of conductivity is mS/cm (or uS/cm);

Request frame: 08 03 00 00 00 04 45 BE

Response frame: 08 03 08 01 02 00 01 00 B0 00 01 90 48

Example of reading:

Conductivity value	Temperature value
01 02 00 01	00 B0 00 01

For example: Salinity value 01 02 means hexadecimal reading salinity value, 00 01 means

the salinity value has no decimal point , which is converted to the decimal value of 25.8.

The temperature value 00 B0 represents the hexadecimal reading temperature value, and 00 01 indicates that the temperature value has a decimal point and is converted to a decimal value of 17.6.

b) Calibration instructions

Zero calibration

Function: Set the sensor's conductivity zero calibration value; here the zero calibration is performed in the air;

Request frame: 08 06 10 00 00 00 8C BD

Response frame: 08 06 10 00 00 00 8C BD

Slope calibration

Function: Set the sensor's conductivity slope calibration value; here the slope value is based on the actual standard solution value, and the calibration is taken as an example with 5000 μ S/cm;

Request frame: 08 06 10 04 01 F4 CD 6B

Response frame: 08 06 10 04 01 F4 CD 6B

c) Set the device ID address:

Function: set the Modbus device address of the sensor;

Change the device address 08 to 01. The example is as follows:

Request frame: 08 06 20 02 00 01 E3 BD

Response frame: 08 06 20 02 00 01 E3 BD

5. Error response

If the sensor does not correctly execute the host command, it will return the following format information:

Definition	Address	Function code	Code	CRC check
Data	ADDR	COM+80H	xx	CRC 16
Number of bytes	1	1	1	2

a) CODE: 01 –Function code error

03 – Data is wrong

b) COM: The received function code