NBL-FUV- 408 Online Full Spectrum Multi-Parameter Sensor User Manual



Changsha Zoko Link Technology Co., Ltd.

Tel:+8615367865107

E-mail: sales@niubol.com

Website: www.niubol.com

Address: Room 102, District D, Houhu Industrial Park,
Yuelu District, Changsha City, Hunan Province, China

User Notice

- Please read this instruction manual carefully before use and keep it for reference.
- Please follow the operating procedures and precautions in this manual.
- When you receive the instrument, please open the package carefully and check whether the instrument and accessories are damaged during transportation. If damage is found, please notify the manufacturer and dealer immediately and keep the packaging for return processing.
- When the instrument breaks down, please do not repair it by yourself, please contact the manufacturer's after-sales department directly.

Contents

I.How it works	4
II.Technical performance and specifications	5
1. Technical Parameters	5
2. Dimensions	6
III.Installation and electrical connections	7
1. Installation	7
2. Electrical Connections	7
IV.Maintenance and care	8
1. Maintenance schedule and methods	8
2. Sensor Calibration	9
3. Precautions	9
4. Common Problems and Solutions	9
V.Quality and Service	9
1. Quality assurance	9
2. Accessories and spare parts	10
3. After-sales service commitment	10
Appendix Data Communication	10

I.How it works

Any substance will absorb light of a specific wavelength. Therefore, by measuring the degree to which these substances absorb specific wavelengths of light, the content of the substance dissolved in water can be accurately measured. The FUV-408 online full -spectrum multi-parameter sensor uses a xenon lamp as a light source, which can emit light of all wavelengths from near ultraviolet to near infrared. It collects full-range spectral information through a micro-fiber spectrometer. In addition, it compensates for the attenuation of the optical path through a specific algorithm and can eliminate the interference of particulate suspended impurities to a certain extent, thereby achieving more stable and reliable measurement.

Features:

- No reagents required, no pollution, economical and environmentally friendly
- Installation is more convenient, and water quality monitoring can be performed online continuously
- Can measure COD, BOD, TOC, color, turbidity , TP, TN, NHN, nitrate, nitrite and other parameters
- Automatic compensation for turbidity interference
- Small drift, fast response, more accurate measurement
- Excellent stability even for long-term monitoring
- Maintenance-free, long service life, low cost
- Digital sensor, RS-485 interface, Modbus/RTU protocol
- Low power consumption design, anti-interference design

II. Technical performance and specifications

1. Technical Parameters

model	NBL-FUV- 408				
Measuring principle	Full spectrum absorption method				
Range	COD	Chroma	TOC	Turbidity	BOD
	0~ 200mg/L equiv. KHP	0~500Hazen	0~150mg/L	0 ~ 400NTU	0~150mg/L
Range	TP	TN	NHN	Nitrates	Nitrite
	0~15 mg/L	0~100 mg/L	0~80 mg/L	0~15 mg/L	0~10 mg/L
COD Accuracy	±5%FS				
COD resolution	0.1mg/L				
Chromaticity accuracy	±5%FS				
Chroma resolution	0.1 Hazen				
TOC accuracy	±5%FS				
TOC resolution	0.1mg/L				
Turbidity accuracy	±5%FS				
Turbidity resolution	0.1NTU				
BOD accuracy	±5%FS				
BOD resolution	0.1mg/L				
TP accuracy	±5%FS				
TP resolution	0.1mg/L				
TN accuracy	±5%FS				
TN resolution	0.1mg/L				
NHN Accuracy	±5%FS				
NHN	0.1mg/L				

resolution	
Nitrate accuracy	±5%FS
Nitrate resolution	0.01mg / L
Nitrite accuracy	±5%FS
Nitrite resolution	0.01mg / L
Calibration	Spectral calibration
Output signal	RS-485 (Modbus/RTU)
Power supply	12VDC
Power consumption	5W@12V
Working conditions	0~45°C、<0.1MPa
Storage temperature	-5~65°C
Protection grade	IP68
Installation	Immersion installation
Cable length	5 meters, other lengths can be customized
Wetted material	316L Stainless Steel

2. Dimensions

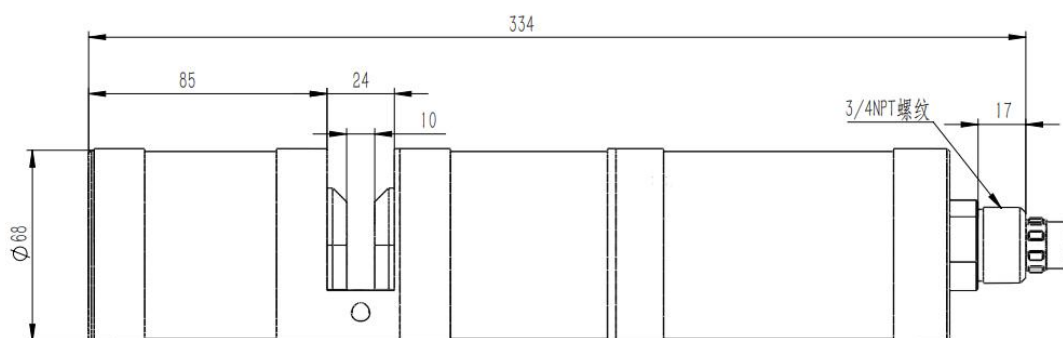

Note: The sensor connector is a male M16-5-core waterproof connector.

III. Installation and electrical connections

1. Installation

When hanging the sensor, avoid hitting the wall or other water conservancy facilities due to water flow. If the water flow is strong, please fix the sensor.

Install the sensor at a depth of no more than 2 meters from the water.

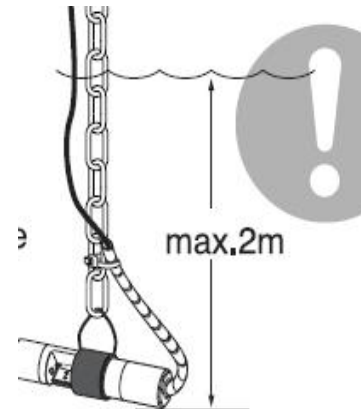
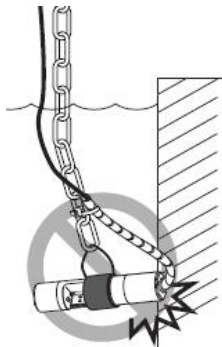

Considering the fluctuation of water level, lower the sensor to 30cm below the lowest possible water level.

Place the sensor in the water where there are no bubbles.

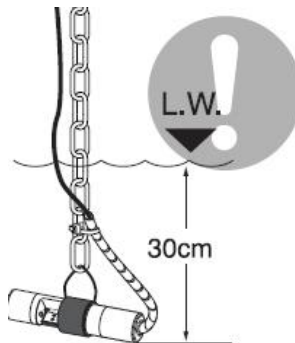

It is recommended to install a cable protective cover over the sensor cable. The sensor is placed horizontally and fixed securely, with the measurement area facing the water flow direction.

2. Electrical Connections

The cable is a 4-core twisted pair shielded cable, and the line sequence definition is:

- Red line - power line (12 ~ 24VDC)
- Black wire - ground wire (GND)

- Blue line—485A
- White line—485B

The wiring sequence should be carefully checked before powering on to avoid unnecessary losses due to wiring errors.

Wiring instructions: Considering that the cables are immersed in water (including seawater) or exposed to the air for a long time, all wiring points are required to be waterproofed and the user cables should have a certain degree of corrosion resistance.

IV.Maintenance and care

1. Maintenance schedule and methods

1.1 Maintenance Schedule

To ensure accurate measurement, cleaning is very important. Regular cleaning of the sensor helps to stabilize the data.

Maintenance tasks	Recommended maintenance frequency
Calibrate sensors (if required by the competent authority)	According to the maintenance schedule required by the competent authority
Maintain and inspect the self-cleaning brushes	Return to factory for inspection and maintenance every 18 months Self-cleaning brush

Note: The maintenance frequency in the above table is only a suggestion. Please clean the sensor according to the actual use of the sensor.

1.2 Maintenance methods

1) Sensor outer surface: Clean the outer surface of the sensor with tap water. If there are still debris remaining, wipe it with a damp soft cloth. For some stubborn dirt, add some household detergent to the tap water to clean it.

2) Check the sensor cable: The cable should not be tight during normal operation, otherwise it is easy to break the wires inside the cable, causing the sensor to not work properly.

3) Check whether the measuring window of the sensor is dirty and whether the cleaning brush is normal.

4) Check whether the cleaning brush of the sensor is damaged.

5) After 18 months of continuous use, the dynamic seal must be replaced.

1.3 Precautions

The sensor contains sensitive optical and electronic components. Ensure that the sensor is not exposed to severe mechanical shocks. There are no user-serviceable parts inside the sensor.

2. Sensor Calibration

Before use, place the sensor in deionized water to ensure that the optical path is completely immersed in water and there are no bubbles. Send the spectrum calibration command to complete the calibration.

3. Precautions

- Avoid sun exposure
- Please do not touch the sensor with your hands
- Avoid bubbles adhering to the sensor surface during measurement and calibration
- Avoid applying any mechanical stress (pressure, scratches, etc.) directly to the sensor during use.

4. Common Problems and Solutions

question	Possible causes	Workaround
The operation interface cannot connect or does not display measurement results	Controller and cable connection error	Reconnect the controller and cables
	Cable failure	Contact us
The measured value is too high, too low, or the value is constantly unstable	The sensor window is attached to foreign objects	Clean the sensor window surface
	Sensor self-cleaning damage	Replace the cleaning brush

V. Quality and Service

1. Quality assurance

- The quality inspection department has standardized inspection procedures, equipped with advanced and complete testing equipment and methods, and strictly inspects according to the procedures, conducts 72-hour aging tests and stability tests on products, and does not allow any unqualified products to leave the factory.

- The consignee will directly return the product batches with a non-conforming rate of 2%,

and all the expenses will be borne by the supplier. The consideration criteria refer to the product description provided by the supplier.

- Supply quantity and delivery speed are guaranteed.

2. Accessories and spare parts

This product includes:

- 1 sensor
- 1 instruction manual
- 1 certificate

3. After-sales service commitment

Our company provides after-sales service for this machine within one year from the date of sale, but does not include damage caused by improper use. If repair or adjustment is required, please send it back, but the shipping fee is at your own expense. When sending it back, please make sure that the packaging is good to avoid damage during transportation. Our company will repair the damage to the instrument free of charge.

Appendix Data Communication

1. Data Format

The default data format for Modbus communication is: 9600, n, 8, 1 (baud rate 9600bps, 1 start bit, 8 data bits, no parity, 1 stop bit).

2. Information frame format (xx represents a byte)

a) Read data command frame

64	03	xx	xx	xx	xx	xx	xx
Address	Function Code	Register Starting	Address	Register Quantity	CRC Check	Code	

(Low Byte First)

b) Read data response frame

64	03	xx	xx.....xx	xx	xx
Address	Function Code	Byte Number	Response Data	CRC Check	Code (Low

Byte First)

c) Write data command frame

64 06 XX XX XX XX XX XX
 Address Function code register address write data CRC check code (low byte
 first)

d) Write data response frame

64 06 XX XX XX XX XX XX
 Address Function code register address write data CRC check code (low byte
 first)

3. Register Address

Register Address	Name	Description	Number of Registers (Bytes)	Access Method (Function Code)
0x0000 (40001)	COD Measurement Value	2 double - byte integers, which are the measurement value and the number of decimal places of the measurement value respective	2 (4 bytes)	Read (0x03)
0x0002 (40003)	BOD Measurement Value	2 double - byte integers, which are the measurement value and the number of decimal places of the measurement value respective	2 (4 bytes)	Read (0x03)
0x0004 (40005)	TOC Measurement Value	2 double - byte integers, which are the measurement value and the number of decimal places of the measurement value respective	2 (4 bytes)	Read (0x03)
0x0006 (40007)	Turbidity Measurement Value	2 double - byte integers, which are the measurement value and the number of decimal places of the measurement value respective	2 (4 bytes)	Read (0x03)
0x0008 (40009)	Chromaticity Measurement Value	2 double - byte integers, which are the measurement value and the number of decimal places of the measurement value respective	2 (4 bytes)	Read (0x03)
0x000A (40011)	Nitrate Nitrogen Measurement Value	2 double - byte integers, which are the measurement value and the number of decimal places of the	2 (4 bytes)	Read (0x03)

		measurement value respective		
0x000C (40013)	Nitrite Measurement Value	2 double - byte integers, which are the measurement value and the number of decimal places of the measurement value respective	2 (4 bytes)	Read (0x03)
0x000E (40015)	Total Nitrogen Measurement Value	2 double - byte integers, which are the measurement value and the number of decimal places of the measurement value respective	2 (4 bytes)	Read (0x03)
0x0010 (40017)	Total Phosphorus Measurement Value	2 double - byte integers, which are the measurement value and the number of decimal places of the measurement value respective	2 (4 bytes)	Read (0x03)
0x0012 (40019)	Ammonia Nitrogen Measurement Value	2 double - byte integers, which are the measurement value and the number of decimal places of the measurement value respective	2 (4 bytes)	Read (0x03)
0x0014 (40021)	CODMn Measurement Value	2 double - byte integers, which are the measurement value and the number of decimal places of the measurement value respective	2 (4 bytes)	Read (0x03)
0x0016 (40023)	UV254 Measurement Value	2 double - byte integers, which are the measurement value and the number of decimal places of the measurement value respectivel	2 (4 bytes)	Read (0x03)
0x0200 (40513)	COD Measurement Value	Float, Little- endian mode	2 (4 bytes)	Read (0x03)
0x0202 (40515)	BOD Measurement Value	Float, Little- endian mode	2 (4 bytes)	Read (0x03)
0x0204 (40517)	TOC Measurement Value	Float, Little- endian mode	2 (4 bytes)	Read (0x03)
0x0206 (40519)	Turbidity Measurement Value	Float, Little- endian mode	2 (4 bytes)	Read (0x03)
0x0208	Chromaticity	Float, Little- endian mode	2 (4 bytes)	Read (0x03)

(40521)	Measurement Value			
0x020A (40523)	Nitrate Nitrogen Measurement Value	Float, Little- endian mode	2 (4 bytes)	Read (0x03)
0x020C (40525)	Nitrite Measurement Value	Float, Little- endian mode	2 (4 bytes)	Read (0x03)
0x020E (40527)	Total Nitrogen Measurement Value	Float, Little- endian mode	2 (4 bytes)	Read (0x03)
0x0210 (40529)	Total Phosphorus Measurement Value	Float, Little- endian mode	2 (4 bytes)	Read (0x03)
0x0212 (40531)	Ammonia Nitrogen Measurement Value	Float, Little- endian mode	2 (4 bytes)	Read (0x03)
0x0214 (40533)	CODMn Measurement Value	Float, Little- endian mode	2 (4 bytes)	Read (0x03)
0x0216 (40535)	UV254 Measurement Value	Float, Little- endian mode	2 (4 bytes)	Read (0x03)
0x2002	Device Address	Int	1 (2 bytes)	Read (0x03) / Write (0x06)
0x1000	Calibration Reference Light	Write 0	1	Write (0x06)
0x1001	Calibration of COD Zero Point		1	Read (0x03) / Write (0x06)
0x1002	Calibration of COD Slope		1	Read (0x03) / Write (0x06)
0x1003	Calibration of BOD Zero Point		1	Read (0x03) / Write (0x06)
0x1004	Calibration of BOD Slope		1	Read (0x03) / Write (0x06)
0x1005	Calibration of TOC Zero Point		1	Read (0x03) / Write (0x06)
0x1006	Calibration of TOC Slope		1	Read (0x03) / Write (0x06)
0x1007	Calibration of NTU Zero Point		1	Read (0x03) / Write (0x06)
0x1008	Calibration of NUT		1	Read (0x03) / Write

	Slope			(0x06)
0x1009	Calibration of Chromaticity Zero Point		1	Read (0x03) / Write (0x06)
0x100A	Calibration of Chromaticity Slope		1	Read (0x03) / Write (0x06)
0x100B	Calibration of NO3 Zero Point		1	Read (0x03) / Write (0x06)
0x100C	Calibration of NO3 Slope		1	Read (0x03) / Write (0x06)
0x100D	Calibration of NO2 Zero Point		1	Read (0x03) / Write (0x06)
0x100E	Calibration of NO2 Slope		1	Read (0x03) / Write (0x06)
0x100F	Calibration of TN Zero Point		1	Read (0x03) / Write (0x06)
0x1010	Calibration of TN Slope		1	Read (0x03) / Write (0x06)
0x1011	Calibration of TV Zero Point		1	Read (0x03) / Write (0x06)
0x1012	Calibration of TP Slope		1	Read (0x03) / Write (0x06)
0x1013	Calibration of TNH Zero Point		1	Read (0x03) / Write (0x06)
0x1014	Calibration of NHN Slope		1	Read (0x03) / Write (0x06)
0x1015	Calibration of CODMn Zero Point		1	Read (0x03) / Write (0x06)
0x1016	Calibration of CODMn Slope		1	Read (0x03) / Write (0x06)
0x1020	Standard Solution and On-site Algorithm Switch	0--Standard Solution 1--On site		Write (0x06)
0x1021	On-site Calibration	Write the actual water sample		Write (0x06)

	of COD	concentration*100		
0x1022	On-site Calibration of BOD	Write the actual water sample concentration*100		Write (0x06)
0x1023	On-site Calibration of TOC	Write the actual water sample concentration*100		Write (0x06)
0x1024	On-site Calibration of NTU	Write the actual water sample concentration*100		Write (0x06)
0x1025	On-site Calibration of COL	Write the actual water sample concentration*100		Write (0x06)
0x1026	On-site Calibration of NO3	Write the actual water sample concentration*100		Write (0x06)
0x1027	On-site Calibration of NO2	Write the actual water sample concentration*100		Write (0x06)
0x1028	On-site Calibration of TN	Write the actual water sample concentration*100		Write (0x06)
0x1029	On-site Calibration of TP	Write the actual water sample concentration*100		Write (0x06)
0x102A	On-site Calibration of NHN	Write the actual water sample concentration*100		Write (0x06)
0x102B	On-site Calibration of Mn	Write the actual water sample concentration*100		Write (0x06)
0x1030	Turbidity Compensation for COD	Write the value as the coefficient *1000		Read (0x03) / Write (0x06)
0x1031	Turbidity Compensation for BOD	Write the value as the coefficient *1000		Read (0x03) / Write (0x06)
0x1032	Turbidity Compensation for TOC	Write the value as the coefficient *1000		Read (0x03) / Write (0x06)
0x1033	Turbidity Compensation for COL	Write the value as the coefficient *1000		Read (0x03) / Write (0x06)
0x1034	Turbidity	Write the value as the coefficient		Read (0x03) / Write

	Compensation for NO3	*1000		(0x06)
0x1035	Turbidity Compensation for NO2	Write the value as the coefficient *1000		Read (0x03) / Write (0x06)
0x1036	Turbidity Compensation for TN	Write the value as the coefficient *1000		Read (0x03) / Write (0x06)
0x1037	Turbidity Compensation for TP	Write the value as the coefficient *1000		Read (0x03) / Write (0x06)
0x1038	Turbidity Compensation for NHN	Write the value as the coefficient *1000		Read (0x03) / Write (0x06)
0x1039	Turbidity Compensation for Mn	Write the value as the coefficient *1000		Read (0x03) / Write (0x06)

4. Command Examples

a) Measurement instructions:

Function: Read the COD value and temperature value of the sensor; the unit of COD value is mg/L, and the unit of temperature is °C.

Request frame: 64 03 00 00 00 04 4 D FC

Response frame: 64 03 08 03 62 00 01 00 B9 00 01 54 2C

Example readings:

Chroma value	COD value
03 62 00 01	00 B9 00 01

For example, the COD value 03 62 represents the hexadecimal reading COD value, and 00 01 represents the COD with 1 decimal point, which is converted into a decimal value of 86.6.

The BOD value 00 B9 indicates the hexadecimal reading of the BOD value, and 00 01 indicates the BOD value has 1 decimal point, which is converted into a decimal value of 18.5.

b) Calibration instructions:

Spectral calibration

Function: To calibrate the sensor reference spectrum; spectrum calibration should be performed after the spectrum has been stable for a period of time.

Request frame: 64 06 10 00 00 00 8 4 FF

Response frame: 64 06 10 00 00 00 8 4 FF

-
- c) To change the device ID address:
Function: Change the Modbus device address of the sensor.
the sensor address 100 to 01, as shown below:
Request frame: 64 06 20 02 00 01 E B FF
Response frame: 64 06 20 02 00 01 E B FF

5. Error Response

If the sensor cannot correctly execute the host computer command, it will return the following format information:

Definition	Address	Function code	CODE	CRC Check
Data	ADDR	COM+80H	xx	CRC 16
Number of bytes	1	1	1	2

- a) CODE: 01 – Function code error
03 – Wrong data
b) COM: the function code you received