

NBL-NHN-406-S Online Ammonia Nitrogen Sensor User Manual



Changsha Zoko Link Technology Co., Ltd.

Tel:+8615367865107

E-mail: sales@niubol.com

Website: www.niubol.com

Address: Room 102, District D, Houhu Industrial Park, Yuelu District, Changsha City,

Hunan Province, China

User Notes

- Please read the instructions carefully before using and save it for reference.
- Please follow the instructions and precautions.
- When receiving the instrument, please open the packaging carefully, inspect equipment's damage level in case of transportation, if you found spoiled equipment, please immediately notify the manufacturer and distributor, and retain the packaging, in order to send back to processing.
- When the instrument is in trouble, please don't repair it by yourself, please directly contact the maintenance department of the manufacturer.

Content

I、	Application environment	4
II、	Technical performance and specifications	4
1.	Technical parameters	4
2.	Dimensional drawing	5
III、	Installation and electrical connection	5
1.	Installation	5
2.	Electrical connection	6
IV、	Maintenance	6
1.	Use and maintenance	6
2.	Sensor calibration	7
V、	Quality and service	7
1.	Quality assurance	7
2.	Accessories and spare parts	7
3.	After sales service commitment	8
Appendix	data Communication	8

I、 Application environment

NHN-406 integrated online ammonia nitrogen sensor is fabricated using a PVC membrane-based ammonium ion selective electrode for testing ammonium ion content in water with temperature compensation to ensure fast, simple, accurate and economical testing. The technical parameters, maintenance and communication protocols of the ammonia nitrogen sensor are described in detail in this user manual.

- Signal output: RS-485 bus, Modbus/RTU protocol, convenient to connect to PLC, DCS, industrial control computer, general controller, paperless recording instrument or touch screen and other third-party equipment.
- The patented ammonium ion probe, the internal reference solution oozes extremely slowly from the microporous salt bridge at a pressure of at least 100 KPa (1 Bar). Such a reference system is very stable and has a longer electrode life than conventional industrial electrodes.
- Easy to install: 3/4 NPT thread (pipe thread) for easy submersible installation or installation in pipes and tanks.
- IP68 protection level.

II、 Technical performance and specifications

1. Technical parameters

Model	NBL-NHN-406-S	
Measuring range and Resolution	0~100.00mg/L	0.01mg/L
	0~1000.0mg/L	0.1mg/L
Accuracy	±10% or ±1mg/L, ±0.5°C	
Working temperature	-5~40°C	
Working pressure	0~40°C, <0.1MPa	
Medium PH range	4~10 pH	
Temperature compensation	Temperature compensation (Pt1000)	
Power supply	12~24VDC	
Signal output	RS-485 & 4-20mA(Optional)	
Wetted material	POM and 316L stainless steel	
Installation	3/4NPT thread, immersion installation	
Cable length	5 meters, can be customized	
Calibration	Two-point calibration	
Power consumption	0.2W@12V	
Protection grade	IP68	

2. Dimensional drawing

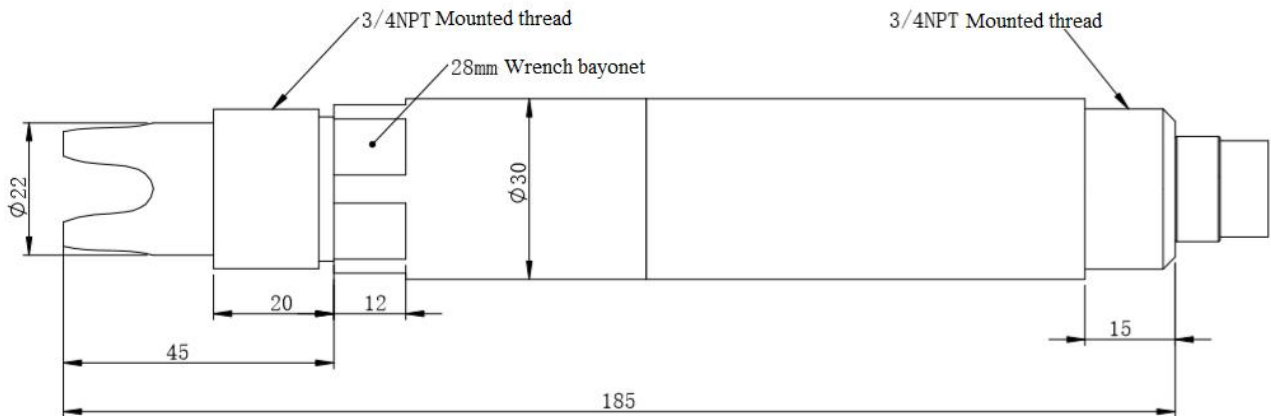

Note: The sensor joint is M16-5 core waterproof joint male

III、 Installation and electrical connection

1. Installation

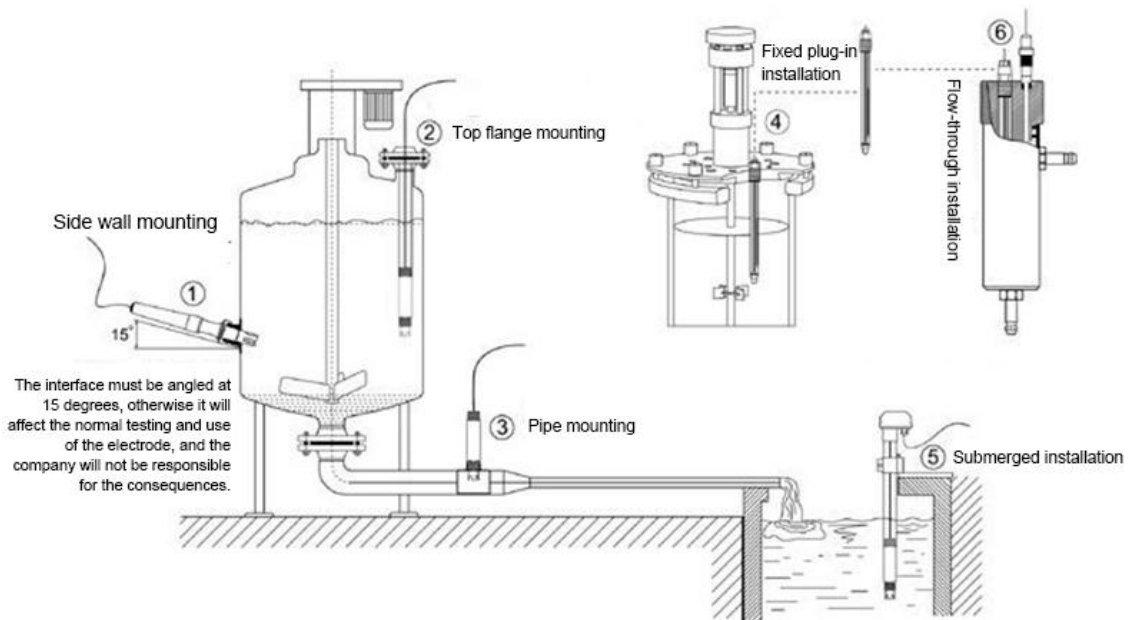

Note: The sensor should not be installed upside down or horizontally when installed, at least at an angle of 15 degrees or more.

2. Electrical connection

The cable is 5-core twisted pair shielded wire, the wire sequence definition:

- Red cord—power cord (12V~24VDC)
- Black cord—ground cord (GND)
- Blue cord—485A
- Green cord—485B
- Yellow cord—Current output (if unused, suspended)

The wiring sequence should be carefully checked before power-on to avoid unnecessary losses caused by faulty wiring.

Wiring instructions: considering the cable long-term Immersion in water (including sea water) or exposure to air, all wiring are required to do waterproof treatment, the user cable should have a certain degree of corrosion resistance.

IV、 Maintenance

1. Use and maintenance

Before the test, the electrode should be immersed in the activation solution for 24 hours, after the activation is completed, in the deionized water clean. Long-term (more than two weeks) do not use the electrodes to dry storage, the electrodes of the induction components should be put into the protective cap.

Check whether the terminal is dry, if there is any contamination, please use absolute alcohol wipe, blow-dry after use. Long-term immersion in distilled water or protein solutions should be avoided and contact with silicone grease should be avoided. With longer electrodes, the PVC film may become translucent or deposit with it, which can be washed with distilled (or deionized) water. The electrode is used for a long time and the measurement error must be corrected.

When the electrode can not be calibrated and measured by the above methods, it means that the electrode has failed, please replace the electrode.

The main interference ions are shown in the table below:

Interference ion concentration that produces 10% error at different ammonium ion concentrations

Interferences (moles/liter)	10 ⁻⁴ M Ammonium	10 ⁻³ M Ammonium	10 ⁻² M Ammonium
H ⁺	< 2	< 1	< 1
Li ⁺	0.2	0.5	0.5
Na ⁺	0.005	0.08	0.8
K ⁺	7*10 ⁻⁵	6*10 ⁻⁴	6*10 ⁻³
Cs ⁺	0.003	0.05	0.5
Mg ³⁺	> 0.5	> 1	> 1
Ca ²⁺	> 0.2	> 1	> 1

Sr ²⁺	> 0.2	> 1	> 1
Ba ²⁺	> 0.1	> 0.5	> 0.5
Zn ²⁺	0.001	0.01	0.1
N ₂ H ₅ ⁺	> 0.1	> 0.1	>0.1
Bu ₄ N ⁺	1*10 ⁻⁵	1*10 ⁻⁴	1*10 ⁻³

2. Sensor calibration

Note: The sensor has been calibrated before leaving the factory. If it is not beyond the measurement error, it should not be arbitrarily calibrated.

a) Zero calibration

Place the sensor in a vial containing the zero standard solution and wait for 5 minutes. After the value is stable, see if the displayed value is within the error range. If not, perform a zero calibration. Refer to the appendix for calibration instructions.

b) Slope calibration

Place the sensor in a vial containing the standard solution of the slope and wait for 5 minutes. After the value is stable, see if the displayed value is within the error range. If not, the slope calibration is required. Refer to the appendix for calibration instructions.

V、Quality and service

1. Quality assurance

- The quality inspection department has standardized inspection procedures, advanced and perfect testing equipment and means, and strictly in accordance with the regulations, to do 72-hour aging test and stability test on the product, and not to allow one unqualified product to leave the factory.
- The receiving party directly returns the product batch with a failure rate of 2%, and all the costs incurred are borne by the supplier. The reference standard refers to the product description provided by the supplier.
- Guarantee the quantity of goods and the speed of shipment.

2. Accessories and spare parts

This product includes:

- 1 sensor
- 1 copy of the manual
- 1 certificate
- 1 Cable (5 m)
- 1mg/L and 10mg/L calibration solution 100mL or 10mg/L and 100mg/L calibration solution

100mL

- 100mL activation solution before use

3. After –sales service commitment

The company provides local after-sales service within one year from the date of sale, but does not include damage caused by improper use. If repair or adjustment is required, please return it, but the shipping cost must be conceited. Damaged on the way, the company will repair the damage of the instrument for free.

Appendix data Communication

1. Data format

The default data format for Modbus communication is: 9600, n, 8, 1 (baud rate 9600bps, 1 start bit, 8 data bits, no parity, 1 stop bit).

Parameters such as baud rate can be customized.

2. Information frame format

a) Read data instruction frame

06	03	xx xx	xx xx	xx xx
Address	Function code	Register address	Number of registers	CRC check code (low byte first)

b) Read data response frame

06	03	xx	xx.....xx	xx xx
Address	Function code	Bytes	Answer data	CRC check code (low byte first)

c) Write data instruction frame

06	06	xx xx	xx xx	xx xx
Address	Function code	Register address	Write data	CRC check code(low byte first)

d) Write data response frame (same data command frame)

06	06	xx xx	xx xx	xx xx
Address	Function code	Register address	Write data	CRC check code (low byte first)

3. Register address

Register address	Name	Instruction	Number of registers	Access method
------------------	------	-------------	---------------------	---------------

<p>40001 (0x0000)</p>	<p>Ammonium ion value + temperature</p>	<p>4 double-byte integers, which are ammonium ion measurement values, measured value decimal places, temperature values, and temperature value decimal places.</p>	<p>4 (8 bytes)</p>	<p>Read</p>
<p>44097 (0x1000)</p>	<p>Zero calibration</p>	<p>Calibrated in a 1 mg/L or 10mg/L standard solution, 0-100 mg/L the data written is the value of the standard solution concentration x100, 0-1000 mg/L the data written is the value of the standard solution concentration x10. The read data is the mV value x100 corresponding to the zero point calibration value.</p>	<p>1 (2 bytes)</p>	<p>Write</p>
<p>44101 (0x1004)</p>	<p>Slope calibration</p>	<p>Calibrated in a 10 mg/L or 100mg/L standard, the 100mg/L written data is the value of the standard solution concentration x100, the 1000mg/L written data is the value of the standard solution concentration x10. The read data is the mV value x100 corresponding to the slope calibration value.</p>	<p>1 (2 bytes)</p>	<p>Write</p>

44113 (0x1010)	Temperature value	In solution calibration, write data to the actual temperature x10; Read data for temperature calibration offset x10.	1 (2 bytes)	Write/Read
48195 (0x2002)	Sensor address	Default address is 6, data range is 1-255.	1 (2 bytes)	Write/Read
48225 (0x2020)	factory reset	Restore calibration values to factory settings, write data to 0.	1 (2 bytes)	Write

4. Command example

a) Read the data instruction:

Function: Obtain the ammonia nitrogen value and temperature of the measuring probe; the unit of ammonia nitrogen is mg/L; the unit of temperature is °C.

Request frame: 06 03 00 00 00 04 45 BE

Response frame: 06 03 08 00 55 00 02 01 18 00 01 B3 5D

Example of reading:

Ammonia value	Temperature value
00 55 00 02	01 18 00 01

Such as: ammonia nitrogen value: 00 55 means hexadecimal reading ammonia nitrogen value, 00 02 means ammonia nitrogen value with two decimal places, converted to decimal value of 0.85.

Temperature value: 01 18 indicates the hexadecimal reading temperature value, 00 01 indicates that the temperature value has a decimal number and is converted to a decimal value of 28.0.

b) Calibration instructions:

Zero calibration

Function: Set the ammonia nitrogen zero calibration value of the sensor. Calibrated in a 1 mg/L standard, examples are as follows:

Request frame: 06 06 10 00 00 648D 56

Response frame: 06 06 10 00 00 64 8D 56

Slope calibration

Role: Set the sensor's ammonia nitrogen slope calibration value. Calibrated in a 10 mg/L standard, examples are as follows:

Request frame: 06 06 10 04 03E8 CD C2

Response frame: 06 06 10 04 03 E8 CD C2

c) Set the sensor ID address

Function: Set the sensor's Modbus device address.

Change the device address 06 to 01. The example is as follows

Request frame: 06 06 20 02 00 01 E3 BD

Response frame: 06 06 20 02 00 01 E3BD

5. Error respond

If the sensor does not correctly execute the host command, it will return the following format information:

Definition	Address	Function code	Code	CRC check
Data	ADDR	COM+80H	xx	CRC 16
Number of bytes	1	1	1	2

- a) CODE: 01 –Function code error
03 – Data is wrong
- b) COM: The received function code