

NBL-NON-406-S Online Nitrate Nitrogen Sensor User Manual



Changsha Zoko Link Technology Co., Ltd.

Tel:+8615367865107

E-mail: sales@niubol.com

Website: www.niubol.com

Address: Room 102, District D, Houhu Industrial Park, Yuelu District, Changsha City,

Hunan Province, China

User Notes

- Please read the instruction carefully before using and save it for reference.
- Please follow the instructions and precautions.
- When receiving the instrument, please open the packaging carefully, inspect equipment's damage level in case of transportation, if you found spoiled equipment, please immediately notify the manufacturer and distributor, and retain the packaging, in order to send back to processing.
- When the instrument is in trouble, please don't repair it by yourself, please directly contact the maintenance department of the manufacturer.

Content

User Notes	1
I 、 Application environment	4
II 、 Technical performance and specifications	4
1. Technical parameters	4
2. Dimensional drawing	5
III 、 Installation and electrical connection	5
1. Installation	5
2. Electrical connection	5
IV 、 Maintenance	6
1. Use and maintenance	6
2. Sensor calibration	7
V 、 Quality and service	7
1. Quality assurance	7
2. Accessories and spare parts	7
3. After sales service commitment	8
Appendix data Communication	8

I 、 Application environment

NON-406S integrated online nitrate nitrogen sensor is fabricated using a PVC membrane-based nitrate ion selective electrode for testing nitrate ion content in water with temperature compensation to ensure fast, simple, accurate and economical testing. The technical parameters, maintenance and communication protocols of the nitrate nitrogen sensor are described in detail in this user manual.

- Signal output: RS-485 bus, Modbus/RTU protocol, convenient to connect to PLC, DCS, industrial control computer, general controller, paperless recording instrument or touch screen and other third-party equipment.
- The patented nitrate ion probe, the internal reference solution oozes extremely slowly from the microporous salt bridge at a pressure of at least 100 KPa (1 Bar). Such a reference system is very stable and has a longer electrode life than conventional industrial electrodes.
- The membrane head is replaceable, lower the cost.
- Easy to install: 3/4 NPT thread (pipe thread) for easy submersible installation or installation in pipes and tanks.
- IP68 protection level.

II 、 Technical performance and specifications

1. Technical parameters

Model	NBL-NON-406-S	
Measuring range and Resolution	0~100.00mg/L	0.01mg/L
	0~1000.0mg/L	0.1mg/L
Accuracy	±10% or ±2mg/L, ±0.5℃	
Working temperature	0~40℃	
Working pressure	<0.1MPa	
Medium PH range	2.5~11pH	
Temperature compensation	Temperature compensation (Pt1000)	
Power supply	12~24VDC	
Signal output	RS-485 & 4-20mA(Optional)	
Wetted material	PVC and POM	
Installation	3/4NPT thread, immersion installation	
Cable length	5 meters, can be customized	
Calibration	Two-point calibration	
Power consumption	0.2W@12V	
Protection grade	IP68	

2. Dimensional drawing

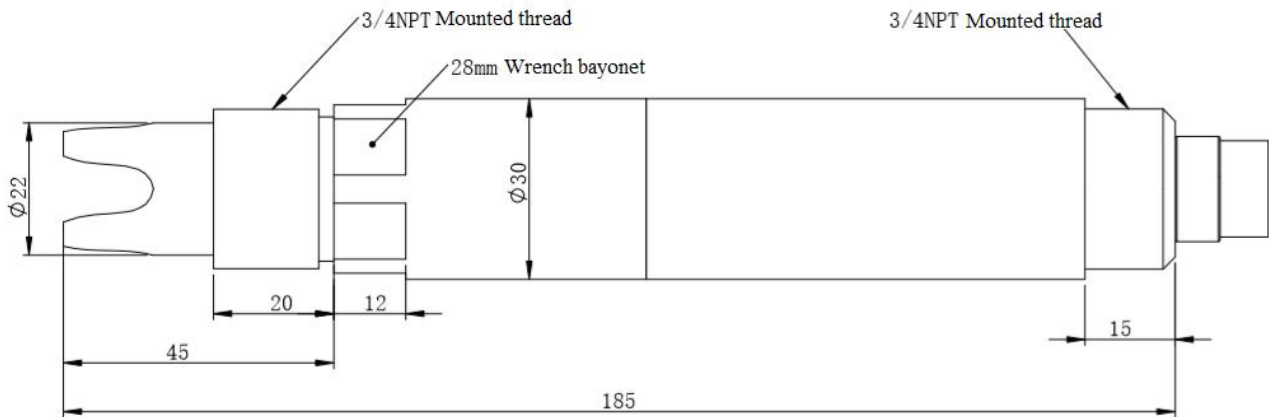

III、 Installation and electrical connection

1. Installation

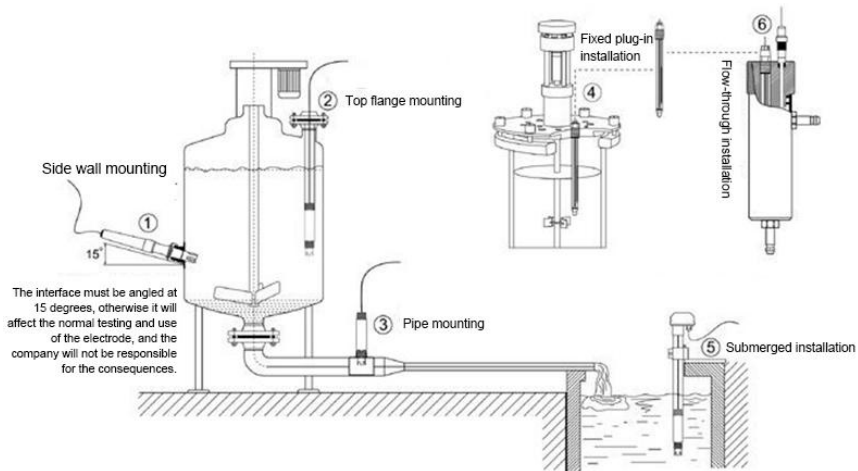

Note: The sensor should not be installed upside down or horizontally when installed, at least at an angle of 15 degrees or more.

2. Electrical connection

- a) Red line - power cord (12 ~ 24V)
- b) Black line - ground (GND)
- c) Blue line - 485A

d) White line - 485B

e) Yellow wire - current output (if not used, can be left open)

After wiring is completed, it should be carefully checked to avoid incorrect connections before powering up.

Cable specification: Considering that the cable is immersed in water (including sea water) for a long time or exposed to the air, all the wiring points are required to do waterproof treatment, the user cable should have certain corrosion resistance.

IV、 Maintenance

1. Use and maintenance

Rinse the electrode in distilled water (or deionized water), blot dry, and do not wipe dry. Place the electrode on the electrode holder. Before use, the tip of the electrode was immersed in tap water 24 hours.

Keep the electrode dry before use. The sensing element of the electrode should be placed in the protective bottle. The electrode should be immersed in the activation solution for 24 hours before testing. If stored overnight or longer, clean the electrode tip with deionized water, wipe dry, and place in the original packaging.

Check if the terminal is dry. If it is stained, wipe it with absolute alcohol and dry it. Avoid long-term immersion in distilled water or protein solution and prevent contact with silicone grease. With longer electrodes, its PVC film may become translucent or with deposits, which can be rinsed with distilled water (or deionized water). The electrode is used for a long time. When a measurement error occurs, it must be calibrated with the meter.

When the calibration and measurement cannot be performed while maintaining and maintaining the electrode in the above manner, the electrode has failed. Please replace the electrode.

The main interference ions are shown in the table below:

Interference ion concentration that produces 10% error at different nitrate ion concentrations

Interferences (moles/liter)	10 ⁻⁴ M Nitrate	10 ⁻³ M Nitrate	10 ⁻² M Nitrate
H ⁺	< 2	< 1	< 1
Li ⁺	0.2	0.5	0.5
Na ⁺	0.005	0.08	0.8
K ⁺	7*10 ⁻⁵	6*10 ⁻⁴	6*10 ⁻³
Cs ⁺	0.003	0.05	0.5
Mg ³⁺	> 0.5	> 1	> 1
Ca ²⁺	> 0.2	> 1	> 1
Sr ²⁺	> 0.2	> 1	> 1
Ba ²⁺	> 0.1	> 0.5	> 0.5
Zn ²⁺	0.001	0.01	0.1

N ₂ H ₅ ⁺	> 0.1	> 0.1	>0.1
Bu ₄ N ⁺	1*10 ⁻⁵	1*10 ⁻⁴	1*10 ⁻³

2. Sensor calibration

Note: The sensor has been calibrated before leaving the factory. If it is not beyond the measurement error, it should not be arbitrarily calibrated.

a) Zero calibration

Place the sensor in a vial containing the zero standard solution and wait for 5 minutes. After the value is stable, see if the displayed value is within the error range. If not, perform a zero calibration.

b) Slope calibration

Place the sensor in a vial containing the standard solution of the slope and wait for 5 minutes. After the value is stable, see if the displayed value is within the error range. If not, the slope calibration is required. Refer to the appendix for calibration instructions.

V、Quality and service

1. Quality assurance

- The quality inspection department has standardized inspection procedures, advanced and perfect testing equipment and means, and strictly in accordance with the regulations, to do 72-hour aging test and stability test on the product, and not to allow one unqualified product to leave the factory.
- The receiving party directly returns the product batch with a failure rate of 2%, and all the costs incurred are borne by the supplier. The reference standard refers to the product description provided by the supplier.
- Guarantee the quantity of goods and the speed of shipment.

2. Accessories and spare parts

This product includes:

- 1 sensor
- 1 copy of the manual
- 1 certificate
- 1mL/L and 10mg/L calibration solution each 100mL

3. After –sales service commitment

The company provides local after-sales service within one year from the date of sale, but does not include damage caused by improper use. If repair or adjustment is required, please return it, but the shipping cost must be conceited. Damaged on the way, the company will repair the damage of the instrument for free.

Appendix data Communication

1. Data format

The default data format for Modbus communication is: 9600, n, 8, 1 (baud rate 9600bps, 1 start bit, 8 data bits, no parity, 1 stop bit).

Parameters such as baud rate can be customized.

2. Information frame format

a) Read data instruction frame

42	03	xx xx	xx xx	xx xx
Address	Function code	Register address	Number of registers	CRC check code (low byte first)

b) Read data response frame

42	03	xx	xx.....xx	xx xx
Address	Function code	Bytes	Answer data	CRC check code (low byte first)

c) Write data instruction frame

42	06	xx xx	xx xx	xx xx
Address	Function code	Register address	Write data	CRC check code(low byte first)

d) Write data response frame (same data command frame)

42	06	xx xx	xx xx	xx xx
Address	Function code	Register address	Write data	CRC check code (low byte first)

3. Register address

Register address	Name	Instruction	Number of registers	Access method
------------------	------	-------------	---------------------	---------------

<p>40001 (0x0000)</p>	<p>Nitrate ion value + temperature</p>	<p>4 double-byte integers, which are ammonium ion measurement values, measured value decimal places, temperature values, and temperature value decimal places.</p>	<p>4 (8 bytes)</p>	<p>Read</p>
<p>44097 (0x1000)</p>	<p>Zero calibration</p>	<p>Calibrate in 10mg/L standard solution if the measuring range is 0-100mg/L , calibrate in 100 mg/L standard solution if the range is 0-1000mg/L; The written data is the value of the used standard solution concentration x10 . The read data is the mV value x100 corresponding to the zero point calibration value.</p>	<p>1 (2 bytes)</p>	<p>Write</p>
<p>44101 (0x1004)</p>	<p>Slope calibration</p>	<p>Calibrate in 100mg/L standard solution if the measuring range is 0-100mg/L, calibrate in 1000mg/L standard solution if the measuring range is 0-1000mg/L; The read data is the mV value x100 corresponding to the slope calibration value.</p>	<p>1 (2 bytes)</p>	<p>Write</p>

44113 (0x1010)	Temperature value	In solution calibration, write data to the actual temperature x10; Read data for temperature calibration offset x10.	1 (2 bytes)	Write/Read
48195 (0x2002)	Sensor address	Default address is 66, data range is 1-255.	1 (2 bytes)	Write/Read
48225 (0x2020)	factory reset	The calibration value returns to the default value, and the written data is 0. Note that the sensor needs to be calibrated again after resetting before it can be used.	1 (2 bytes)	Write

4. Command example

a) Read data instructions:

Function: Get the nitrate ion concentration and temperature measured by the sensor; the unit of nitrate ion concentration is mg/L; the unit of temperature is °C.

Request frame: 42 03 00 00 00 04 4A FA

Response frame: 42 03 08 00 55 00 01 01 18 00 01 B7 AC

Reading example:

Nitrate value	Temperature value
00 55 00 01	01 18 00 01

For example: nitrate and nitrogen value: 00 55 represents the nitrate and nitrogen value in hexadecimal reading, 00 01 represents the nitrate and nitrogen value with one decimal place, and the converted decimal value is 8.5.

Temperature value: 01 18 represents the hexadecimal reading temperature value, 00 01 represents the temperature value with one decimal place, and the converted decimal value is 28.0.

b) Calibration instructions:

Zero point calibration

Function: Set the zero point calibration value of the nitrate sensor. Calibrate in 10mg/L standard solution, the example is as follows:

Request frame: 42 06 10 00 00 64 82 12

Response frame: 42 06 10 00 00 64 82 12

slope calibration

Function: Set the slope calibration value of the nitrate sensor. Calibrate in 100mg/L standard solution, the example is as follows:

Request frame: 42 06 10 04 03 E8 C2 86

Response frame: 42 06 10 04 03 E8 C2 86

c)Set device ID address

Function: Set the Modbus device address of the sensor.

Change the sensor address 42 to 01, the example is as follows

Request frame: 42 06 20 02 00 01 EC F9

Response frame: 42 06 20 02 00 01 EC F9

5. Error respond

If the sensor does not correctly execute the host command, it will return the following format information:

Definition	Address	Function code	Code	CRC check
Data	ADDR	COM+80H	xx	CRC 16
Number of bytes	1	1	1	2

a) CODE: 01 –Function code error

03 – Data is wrong

b) COM: The received function code