

NBL-NOO-406-S Online Nitrite Sensor User Manual



Changsha Zoko Link Technology Co., Ltd.

Tel:+8615367865107

E-mail: sales@niubol.com

Website: www.niubol.com

Address: Room 102, District D, Houhu Industrial Park, Yuelu District, Changsha City,

Hunan Province, China

User Notes

- Please read the instructions carefully before using and save it for reference.
- Please follow the instructions and precautions.
- When receiving the instrument, please open the packaging carefully, inspect equipment's damage level in case of transportation, if you found spoiled equipment, please immediately notify the manufacturer and distributor, and retain the packaging, in order to send back to processing.
- When the instrument is in trouble, please don't repair it by yourself, please directly contact the maintenance department of the manufacturer.

Content

User Notes	2
I. Application Description	4
II. Technical Performance and Specifications	4
2.1 Technical Parameters	4
2.2.Dimension	5
III、 Installation and electrical connection	5
1. Installation	5
2. Electrical Connection	6
IV. Maintenance	6
1. Use and Maintenance	6
2. Sensor Calibration	7
V. Quality and Service	7
1. Quality Assurance	7
2. Accessories and Spare Parts	7
3. After-sales Service Commitment	8
Appendix: Data Communication	8
1. Data Format	8
2. Frame Format	8
3. Register Addresses	9
4. Command Examples	9
5. Error Response	11

I. Application Description

The NBL-NOO-406 integrated online nitrite nitrogen sensor is manufactured using a PVC membrane-based ion-selective electrode, designed for measuring nitrite ion concentration in water. It features temperature compensation to ensure fast, simple, accurate, and cost-effective measurements.

This user manual provides detailed information on the sensor's technical specifications, operation and maintenance, as well as communication protocols.

Signal Output: RS-485 bus with Modbus RTU protocol, enabling convenient connection to third-party devices such as PLC, DCS, industrial control computers, general controllers, paperless recorders, or touch screens.

Patented Nitrite Ion Electrode: The internal reference solution slowly leaks through a microporous salt bridge under a pressure of at least 100 kPa (1 bar). This highly stable reference system significantly extends the electrode lifespan compared to conventional industrial electrodes.

Easy Installation: 3/4" NPT thread, suitable for immersion installation or mounting in pipelines and tanks.

Protection Rating: IP68.

II. Technical Performance and Specifications

2.1 Technical Parameters

Model	NBL-NOO-406-S	
Measuring Principle	Ion-selective method	
Range and Resolution	0~2.000 mg/L	0.001
Accuracy	±5%; ±0.3°C	
Calibration Method	Two-point calibration	
Cleaning Method	/	
Temperature Compensation	Automatic temperature compensation(Pt1000)	
Output Method	RS-485(ModbusRTU)	
Storage Temperature	-5~40°C	
Operating Conditions	0~40°C, ≤0.2MPa	
Housing Material	316L	

Mounting Method	Flush-mounted installation, 3/4NPT
Power Consumption	0.2W@12V
Power Supply	12~24VDC
Protection Rating	IP68

2.2.Dimension

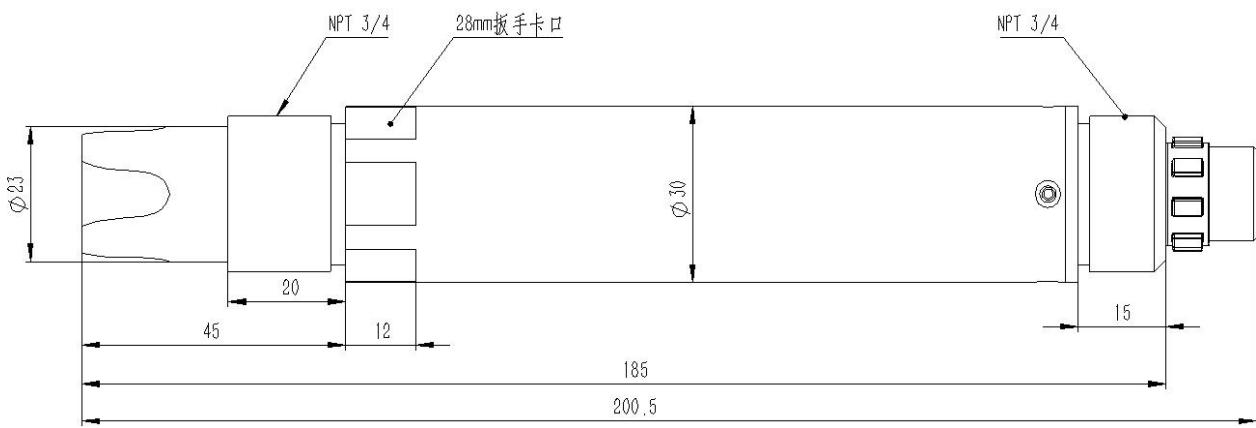

Note: the sensor joint is M16-5 waterproof joint

III、 Installation and electrical connection

1. Installation

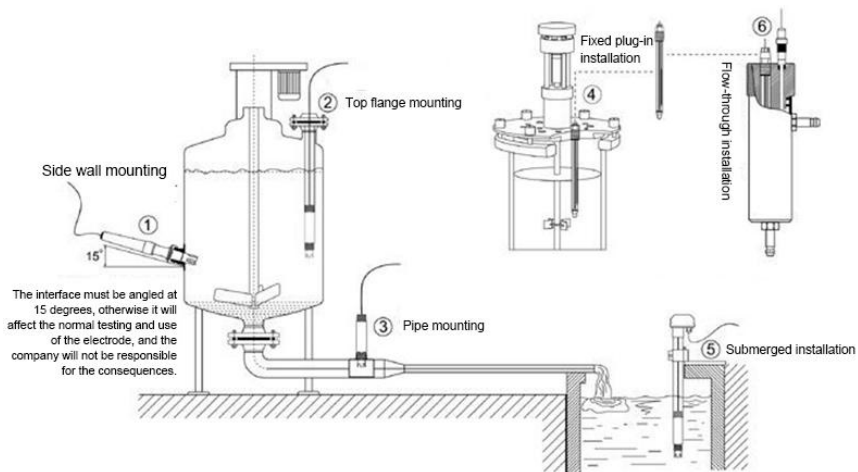

Note: Do not install the sensor upside down or horizontally; install it at an angle of at least 15 degrees.

2. Electrical Connection

The cable is a 5-core twisted shielded cable. The wiring definition is as follows:

- * Red wire — Power supply (12–24 VDC)
- * Black wire — Ground (GND)
- * Blue wire — RS-485 A
- * White wire — RS-485 B
- * Yellow wire — Current output (optional; leave unconnected if not used)

Before powering on, carefully check the wiring sequence to avoid unnecessary damage caused by incorrect connections.

Wiring Notes:

Considering that the cable may be immersed in water (including seawater) for long periods or exposed to air, all wiring connections must be waterproofed. User-supplied cables should have adequate corrosion resistance.

IV. Maintenance

1. Use and Maintenance

Clean the electrode with distilled water (or deionized water), then blot dry. Do not wipe dry. Place the electrode on the electrode holder. Before use, immerse the electrode tip in tap water for 24 hours.

Keep the electrode dry before use. The sensing element should be placed in the protective cap. Prior to measurement, the electrode should be soaked in tap water for 24 hours; powered soaking provides better results.

If stored overnight or longer, rinse the electrode head with deionized water, dry it, and place it back into the original packaging.

Check whether the wiring terminals are dry. If contaminated, wipe with anhydrous alcohol and dry before use. Avoid long-term immersion in distilled water or protein solutions, and prevent contact with silicone grease.

After long-term use, the PVC membrane may become semi-transparent or develop deposits. In this case, rinse with distilled (or deionized) water. If measurement errors occur after extended use, recalibration is required.

If the electrode still cannot be calibrated or measured properly after the above maintenance, it is considered failed and should be replaced.

2. Sensor Calibration

Note: The sensor has been calibrated before leaving the factory. Recalibration is not recommended unless measurement errors exceed the acceptable range.

a) Zero Calibration

Place the sensor into a container with zero standard solution. Wait for 5 minutes until the reading stabilizes. Check whether the displayed value is within the acceptable error range. If not, perform zero calibration. Refer to the appendix for calibration commands.

b) Slope Calibration

Place the sensor into a container with slope standard solution. Wait for 5 minutes until the reading stabilizes. Check whether the displayed value is within the acceptable error range. If not, perform slope calibration. Refer to the appendix for calibration commands.

V. Quality and Service

1. Quality Assurance

* The quality inspection department follows standardized inspection procedures, equipped with advanced testing equipment and methods. All products undergo 72-hour aging tests and stability tests to ensure no defective products leave the factory.

* Product batches with a defect rate of 2% or higher may be returned directly by the buyer, with all related costs borne by the supplier. Inspection standards are based on the product documentation provided by the supplier.

* Supply quantity and delivery speed are guaranteed.

2. Accessories and Spare Parts

This product includes:

- * 1 × Sensor
- * 1 × User Manual
- * 1 × Certificate of Conformity
- * 1 × Cable (5 meters)

3. After-sales Service Commitment

The company provides a one-year warranty from the date of sale. The electrode is a consumable part with a six-month warranty.

Damage caused by improper use is not covered under warranty. If repair or adjustment is required, please return the product at your own shipping cost. Ensure proper packaging to prevent damage during transportation. The company will repair the instrument free of charge.

Appendix: Data Communication

1. Data Format

The default Modbus communication format is: **9600, N, 8, 1**
(Baud rate: 9600 bps, 1 start bit, 8 data bits, no parity, 1 stop bit).

Baud rate and other parameters can be customized.

2. Frame Format

a) Read Data Command Frame

```
45    03    xx xx    xx xx    xx xx  
Addr  Func  Reg Addr Reg Qty  CRC (Low byte first)
```

b) Read Data Response Frame

```
45    03    xx    xx ... xx    xx xx  
Addr  Func  Byte Count  Data  CRC (Low byte first)
```

c) Write Data Command Frame

```
45    06    xx xx    xx xx    xx xx  
Addr  Func  Reg Addr  Data   CRC (Low byte first)
```

d) Write Data Response Frame (same as command frame)

45 06 xx xx xx xx xx xx
 Addr Func Reg Addr Data CRC (Low byte first)

3. Register Addresses

Register address	Name	Instruction	Number of registers	Access method
40001 (0x0000)	Nitrite ion measurement + temperature	Four double-byte integers representing the measured value of the nitrite ion, the number of decimal places for the measured value, the temperature value, and the number of decimal places for the temperature value.	4 (8 bytes)	Read
44097 (0x1000)	Zero calibration	When the measurement range is 0–2 mg/L, calibration must be performed using a 0.02 mg/L standard solution, and the value 20 must be entered.	1 (2 bytes)	Write/Read
44101 (0x1004)	Slope calibration	When the measurement range is 0–2 mg/L, calibration must be performed using a 0.2 mg/L standard solution, and the value entered should be 200.	1 (2 bytes)	Write/Read
44113 (0x1010)	Temperature Calibration	When calibrating in solution, enter the actual temperature value multiplied by 10; the readout will be the temperature calibration offset multiplied by 10.	1 (2 bytes)	Write/Read
48195 (0x2002)	Sensor Address	The default value is 69; the data range is 1 to 255.	1 (2 bytes)	Write/Read

4. Command Examples

a) Read Data Command

Function:

Retrieve the nitrite ion concentration and temperature measured by the sensor.

Nitrite unit: mg/L

Temperature unit: °C

Request Frame:

45 03 00 00 00 04 4B 4D

Response Frame:

45 03 08 00 05 00 03 01 18 00 01 84 1D

Example Interpretation:

Nitrite Value	Temperature Value
00 05 00 03	01 18 00 01

Nitrite Value:

00 05 = raw hexadecimal value

00 03 = decimal precision (3 decimal places)

Converted value = 0.005 mg/L

Temperature Value:

01 18 = raw hexadecimal value

00 01 = decimal precision (1 decimal place)

Converted value = 28.0 °C

b) Calibration Commands

Zero Calibration

Function: Set the zero calibration value of the sensor. Perform calibration in a zero standard solution.

Request Frame:

45 06 10 00 00 64 83 A5

Response Frame:

45 06 10 00 00 64 83 A5

Slope Calibration

Function: Set the slope calibration value of the sensor. Perform calibration in a slope standard solution.

Request Frame:

45 06 10 04 03 E8 C3 31

Response Frame:

45 06 10 04 03 E8 C3 31

c) Set Device ID Address

Function: Set the Modbus device address of the sensor.

Example: Change sensor address from 06 to 01

Request Frame:

45 06 20 02 00 01 ED 4E

Response Frame:

45 06 20 02 00 01 ED 4E

5. Error Response

If the sensor cannot correctly execute the command from the host, it will return a response in the following format:

Definition	Address	Function Code	CODE	CRC Check
Data	ADDR	COM + 80H	xx	CRC16
Bytes	1	1	1	2

a) CODE:

01 – Illegal function

03 – Data error

b) COM:

The function code received from the master device.