

NBL-PHG-406-A Online PH Sensor

User Manual



Changsha Zoko Link Technology Co., Ltd.

Tel:+8615367865107

E-mail: sales@niubol.com

Website: www.niubol.com

Address: Room 102, District D, Houhu Industrial Park, Yuelu District, Changsha City,

Hunan Province, China

User Notes

- Please read the instruction carefully before using and save it for reference.
- Please follow the instructions and precautions.
- When receiving the instrument, please open the packaging carefully, inspect equipment's damage level in case of transportation, if you found spoiled equipment, please immediately notify the manufacturer and distributor, and retain the packaging, in order to send back to processing.
- When the instrument is in trouble, please don't repair it by yourself, please directly contact the maintenance department of the manufacturer.

Content

User Notes	1
I 、 Application Environment	4
II 、 Technical performance and specifications	4
1. Technical parameters	4
2. Dimensional drawing	5
III 、 Installation and electrical connection	5
1. Installation	5
2. Electrical connection	6
IV 、 Maintenance and maintenance	6
1. Use and maintenance	6
2. Calibration	7
V 、 Quality and service	7
1. Quality assurance	7
2. Accessories and spare parts	8
3. After-sales service commitment	8
Appendix data communication	8

I 、 Application Environment

Used for environmental water quality monitoring, acid/alkali/salt solution, chemical reaction process and industrial production process, it can meet the requirements of online pH measurement for most industrial applications.

- Signal output: RS-485 (Modbus/RTU protocol)、4-20mA.
- Convenient connection to third-party devices such as PLCs, DCS, industrial control computers, general-purpose controllers, paperless recording instruments or touch screens.
- Dual high-impedance differential amplifier with strong anti-interference and fast response.
- The patented pH probe, the internal reference solution oozes extremely slowly from the microporous salt bridge at a pressure of at least 100 kpa (1 Bar), and its forward bleed continues for more than 20 months. Such a reference system is very stable and the electrode life is extended by a factor of two compared to conventional industrial electrodes.
- Easy to install: 3/4 NPT pipe thread for easy submersible installation or installation in pipes and tanks.
- IP68 protection grade.

II 、 Technical performance and specifications

1. Technical parameters

Model	NBL-PHG-406-A
Measuring range	0~14pH
Resolution	0.01pH
Accuracy	±0.1pH, ±0.3°C
Working temperature	0~65°C
Working pressure	<0.2MPa
Temperature compensation	Auto temperature compensation (NTC)
Power supply	12~24VDC
Signal output	RS-485(Modbus/RTU)、4-20mA(Optional)
Wetted material	POM
Mounting method	Immersion mounting, 3/4 NPT thread
Cable length	5 meters, other lengths can be customized
Calibration	Two-point calibration
Power consumption	0.2W@12V
Protection grade	IP68

2. Dimensional drawing

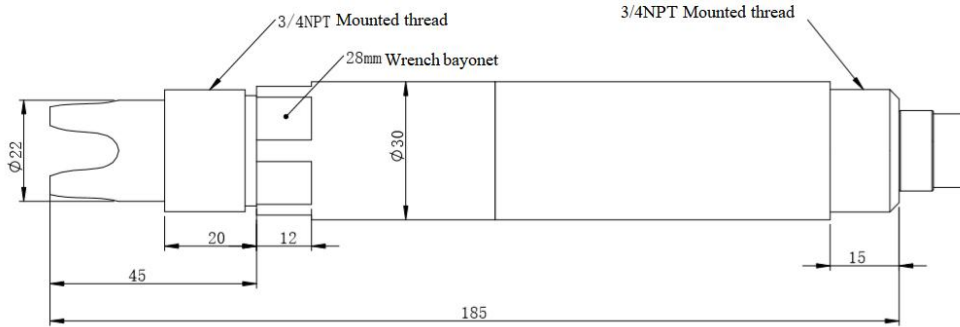

Note: The sensor connector is M16-5 core waterproof joint male head.

III、 Installation and electrical connection

1. Installation

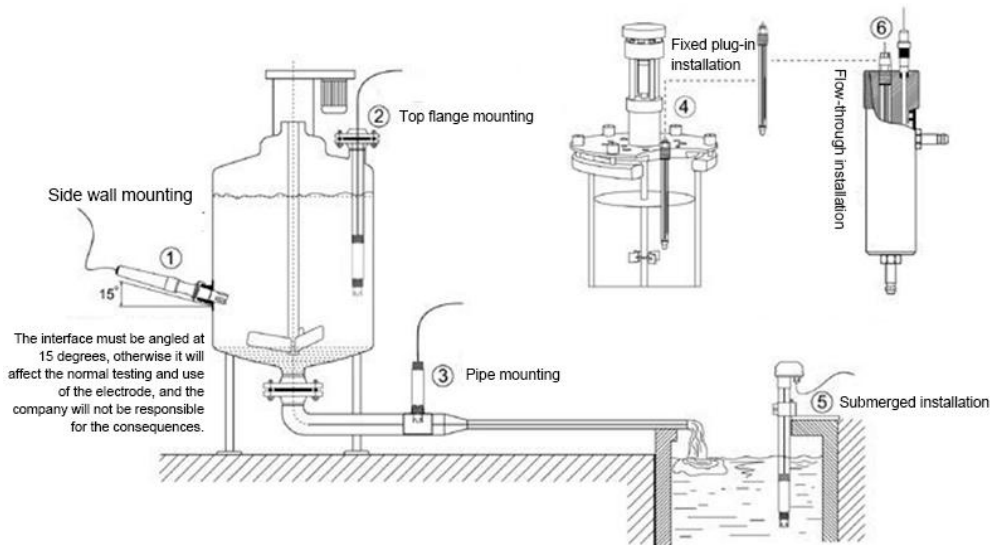

Note: The sensor should not be installed upside down or horizontally when installed, at least at an angle of 15 degrees or more.

2. Electrical connection

- a) Red line - power cord (12 ~ 24V)
- b) Black line - ground (GND)
- c) Blue line - 485A
- d) white line - 485B

E)Yellow wire -- current output (suspended if not in use)

After wiring is completed, it should be carefully checked to avoid incorrect connections before powering up.

Cable specification: Considering that the cable is immersed in water (including sea water) for a long time or exposed to the air, all the wiring points are required to do waterproof treatment, the user cable should has certain corrosion resistance.

IV、 Maintenance

1. Use and maintenance

When using the pH sensor, it should be cleaned in distilled water (or deionized water), and the filter paper should be used to absorb moisture to prevent impurities from being introduced into the liquid to be tested. 1/3 of the sensor should be inserted into the solution to be tested.

The sensor should be washed when not in use, inserted into a protective sleeve with a 3.5 mol/L potassium chloride solution, or the sensor inserted into a container with a 3.5 mol/L potassium chloride solution.

Check if the terminal is dry. If it is stained, wipe it with absolute alcohol and dry it. Avoid long-term immersion in distilled water or protein solution and prevent contact with silicone grease. With a longer sensor, its glass film may become translucent or with deposits, which can be washed with dilute hydrochloric acid and rinsed with water. The sensor is used for a long time. When a measurement error occurs, it must be calibrated with the meter for calibration.

When the calibration and measurement cannot be performed while the sensor is being maintained and maintained in the above manner, the sensor has failed. Please replace the sensor.

Standard buffer pH reference table

Temp(°C)	4.00	4.01	6.86	7.00	9.18	10.01
0	4.00	4.00	6.98	7.12	9.46	10.32
5	4.00	4.00	6.95	7.09	9.39	10.25
10	4.00	4.00	6.92	7.06	9.33	10.18
15	4.00	4.00	6.90	7.04	9.28	10.12
20	4.00	4.00	6.88	7.02	9.23	10.06
25	4.00	4.01	6.86	7.00	9.18	10.01
30	4.01	4.02	6.85	6.99	9.14	9.97
35	4.02	4.02	6.84	6.98	9.10	9.93
40	4.03	4.04	6.84	6.97	9.07	9.89
45	4.04	4.05	6.83	6.97	9.04	9.86
50	4.06	4.06	6.83	6.97	9.02	9.83

The actual reading and standard of the instrument sometimes have an error of ± 1 word.

2. Calibration

Note: The sensor has been calibrated before leaving the factory. If the measurement error is not exceeded, it should not be arbitrarily calibrated.

a) Zero calibration

Use 250 mL of distilled water in a measuring cylinder, pour into a beaker, add a packet of calibration powder with pH=6.86, stir evenly with a glass rod until the powder is completely dissolved, configure the solution with pH=6.86, put the sensor into the solution, wait for 3 ~5 minutes, after the value is stable, see if the displayed value is 6.86. If not, you need to perform zero calibration. Refer to the appendix for the calibration instructions.

b) Slope calibration

For acidic solution: Take 250 mL of distilled water in a measuring cylinder, pour into a beaker, add a packet of calibration powder with pH=4.00, stir evenly with a glass rod until the powder is completely dissolved, and configure the solution to pH=4.00; In the solution, wait for 3 to 5 minutes. After the value is stable, see if the value is 4.00. If not, the slope calibration is required. Refer to the appendix for the calibration instructions.

For alkaline solution: Take 250 mL of distilled water in a measuring cylinder, pour into a beaker, add a packet of calibration powder with pH=9.18, stir evenly with a glass rod until the powder is completely dissolved, and configure the solution to pH=9.18; In the solution, wait for 3 to 5 minutes. After the value is stable, check if the display is 9.18. If not, the slope calibration is required. Refer to the appendix for the calibration instructions.

V 、 Quality and service

1. Quality assurance

- The quality inspection department has standardized inspection procedures, advanced and perfect testing equipment and means, and strictly in accordance with the regulations, to do 72-hour aging test and stability test on the product, and not to allow one unqualified product to leave the factory.
- The receiving party directly returns the product batch with a failure rate of 2%, and all the costs incurred are borne by the supplier. The reference standard refers to the product description provided by the supplier.
- Guarantee the quantity of goods and the speed of shipment.

2. Accessories and spare parts

This product includes:

- 1 sensor
- Calibration powder 3 packs
- 1 copy of the manual
- 1 certificate

3. After-sales service commitment

The company provides local after-sales service within one year from the date of sale, but does not include damage caused by improper use. If repair or adjustment is required, please return it, but the shipping cost must be conceited. Damaged on the way, the company will repair the damage of the instrument for free.

Appendix data communication

1. Data format

The default data format for Modbus communication is: 9600, n, 8, 1 (baud rate 9600bps, 1 start bit, 8 data bits, no parity, 1 stop bit).

Parameters such as baud rate can be customized.

2. Information frame format

a) Read data instruction frame

03	03	xx xx	xx xx	xx xx
Address	Function code	Register address	Number of registers	CRC check code (low byte first)

b) Read data response frame

03	03	xx	xx.....xx	xx xx
Address	Function code	Bytes	Answer data	CRC check code (low byte first)

c) Write data instruction frame

03	06	xx xx	xx xx	xx xx
Address	Function code	Register address	Write data	CRC check code(low byte first)

d) Write data response frame (same data command frame)

03	06	xx xx	xx xx	xx xx
Address	Function code	Register address	Write data	CRC check code (low byte first)

3. Register address

Register address	Name	Instruction	Number of registers	Access method
40001 (0x0000)	Measured value + temperature	4 double-byte integers, which are DO value, DO value decimal digits,	4 (8 bytes)	Read

		temperature value, temperature value decimal digits.		
44097 (0x1000)	Zero calibration	In the standard solution PH 6.86 in the calibration data is written to zero.	1 (2 bytes)	Write
44099 (0x1002)	Slope calibration (4PH)	Calibrate with a standard pH of 4.00 and write data to zero.	1 (2 bytes)	Write
44101 (0x1004)	Slope calibration (9.18PH)	Calibrate with a standard pH of 9.18 and write data to zero.	1 (2 bytes)	Write
44103 (0x1006)	Zero calibration value	Returns the zero calibration value.	1 (2 bytes)	Read
44105 (0x1008)	Slope calibration value	The slope calibration value is multiplied by 1000.	1 (2 bytes)	Read
44113 (0x1010)	Temperature value	In solution calibration, write data to the actual temperature x10; Read data for temperature calibration offset x10.	1 (2 bytes)	Write/Read
48195 (0x2002)	Device address	Default address is 3, data range is 1-255.	1 (2 bytes)	Write/Read
48225 (0x2020)	factory reset	Restore calibration values to factory settings, write data to 0. Note that the sensor must be calibrated again after reset before use.	1 (2 bytes)	Write

4. Command example

a) Read data command

Function: Get the pH and temperature measured by the sensor; the unit of pH is pH; the unit of temperature is ° C.

Request frame: 03 03 00 00 00 04 45 EB;

Response frame: 03 03 08 00 62 00 02 01 01 00 01 35 95

Reading example:

pH value	temperature value
00 62 00 02	01 01 00 01

pH value: 00 62 means hexadecimal reading pH value, 00 02 means pH value with 2 decimal places, converted to decimal value is 0.98.

Temperature value: 01 01 represents the hexadecimal reading temperature value, 00 01 represents the temperature value with 1 decimal place, and the converted decimal value is 25.7.

b) Calibration instructions:

Zero point calibration

Function: Set the pH zero point calibration value of the sensor. The zero point value uses 6.86 pH standard solution as the calibration standard. The example is as follows:

Request frame: 03 06 10 00 00 00 8C E8

Response frame: 03 06 10 00 00 00 8C E8

slope calibration

Function: Set the pH slope calibration value of the sensor; the slope calibration is divided into high point and low point calibration. When the alkaline solution is measured, it is calibrated at the high point; when the acidic solution is measured, it is calibrated at the low point. Here, the height of the standard solution is used. The point 9.18pH and the low point of the standard solution 4.00pH are the calibration reference. Examples are as follows:

High point standard solution 9.18pH calibration:

Request frame: 03 06 10 04 00 00 CD 29

Response frame: 03 06 10 04 00 00 CD 29

Low point standard solution 4.00pH calibration:

Request frame: 03 06 10 02 00 00 2D 28

Response frame: 03 06 10 02 00 00 2D 28

c) Set device ID address:

Function: Set the MODBUS device address of the sensor;

Change the sensor address 03 to 01. The example is as follows:

Request frame: 03 06 20 02 00 01 E3 E8

Response frame: 03 06 20 02 00 01 E3 E8

5. Error response

If the sensor does not correctly execute the host command, it will return the following format information:

Definition	Address	Function code	Code	CRC check
Data	ADDR	COM+80H	xx	CRC 16
Number of bytes	1	1	1	2

a) CODE: 01 –Function code error

03 – Data is wrong

b) COM: The received function code