

# **NBL-TH-406-S Online Total Hardness Sensor User manual**



Changsha Zoko Link Technology Co., Ltd.

Tel:+8615367865107

E-mail: [sales@niubol.com](mailto:sales@niubol.com)

Website: [www.niubol.com](http://www.niubol.com)

Address: Room 102, District D, Houhu Industrial Park, Yuelu District, Changsha City,

Hunan Province, China

## User Notes

- Please read the instructions carefully before using and save it for reference.
- Please follow the instructions and precautions.
- When receiving the instrument, please open the packaging carefully, inspect equipment's damage level in case of transportation, if you found spoiled equipment, please immediately notify the manufacturer and distributor, and retain the packaging, in order to send back to processing.
- When the instrument is in trouble, please don't repair it by yourself, please directly contact the maintenance department of the manufacturer.

## Content

User Notes .....	1
I. Working principle .....	4
II. Technical performance and specifications .....	4
1. Technical parameters .....	4
2. Dimension .....	5
III. Installation and electrical connection .....	5
1. Installation .....	5
2. Electrical connection .....	5
IV. Maintenance .....	6
1. Use and maintenance .....	6
2. Sensor calibration .....	6
V. Quality and service .....	6
1. Quality assurance .....	6
2. Accessories spare and parts .....	7
3. After-sales service commitment .....	7
Appendix data communication .....	8
1. Data format .....	8

## I. Working principle

NBL-TH-406-S integrated online total hardness sensor is made of calcium and magnesium selective electrode based on PVC film. It is used to test the total hardness of water (in CaCO<sub>3</sub>), with temperature compensation, to ensure that the test is fast, simple, accurate and economical. This manual describes the technical parameters, maintenance, and communication protocols of the total hardness sensor in detail.

- signal output: RS - 485 bus, Modbus/RTU protocol, convenient connection to the PLC, DCS, industrial control computer, general controller, paperless record instrument or third party equipment such as touch screen.
- patent of calcium and magnesium ions electrode, the internal reference solution for at least 100 kpa (1 bar), under the pressure of the extremely slow leak out of microporous salt bridge. Such a reference system is very stable and the electrode life is longer than the ordinary industrial electrode life.
- easy to install: 3/4 NPT pipe thread, facilitate submersible installed or installed in pipes and tanks.
- IP68 protection grade.

## II. Technical performance and specifications

### 1. Technical parameters

<b>model</b>	NBL-TH-406-S	
<b>Range and resolution</b>	0~1000.0mg/L	0.1mg/L
<b>precision</b>	±10% of reading; ±0.3°C	
<b>Storage temperature</b>	-5~40°C	
<b>Working conditions</b>	0~40°C, <0.1MPa	
<b>pH range of the medium</b>	4~10pH	
<b>Compensation of temperature</b>	Automatic temperature compensation (Pt1000)	
<b>The power supply</b>	12~24VDC	
<b>Output of signal</b>	RS-485(Modbus/RTU) 、 4-20mA(Optional)	
<b>Material of case</b>	POM and 316L stainless steel	
<b>Installation Mode</b>	3/4NPT pipe thread, immersion mount	
<b>Length of cable</b>	5 meters, other lengths can be customized	
<b>Mode of calibration</b>	Two point calibration	

<b>Power consumption</b>	0.2W@12V
<b>Class of protection</b>	IP68

## 2. Dimension

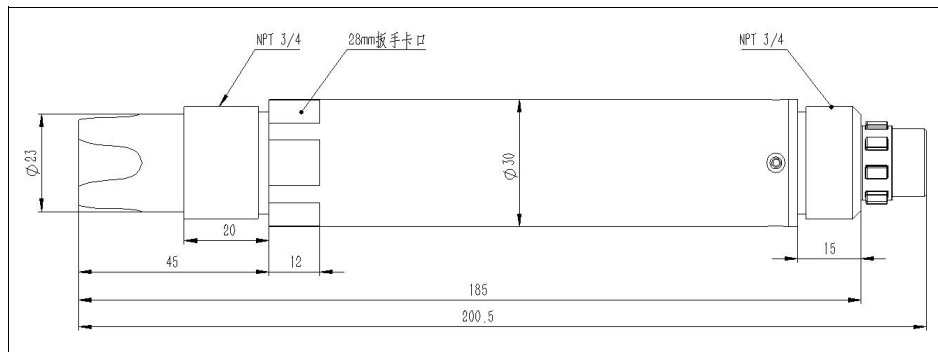

Note: The sensor connector is M16-5 core waterproof connector male head

## III. Installation and electrical connection

### 1. Installation

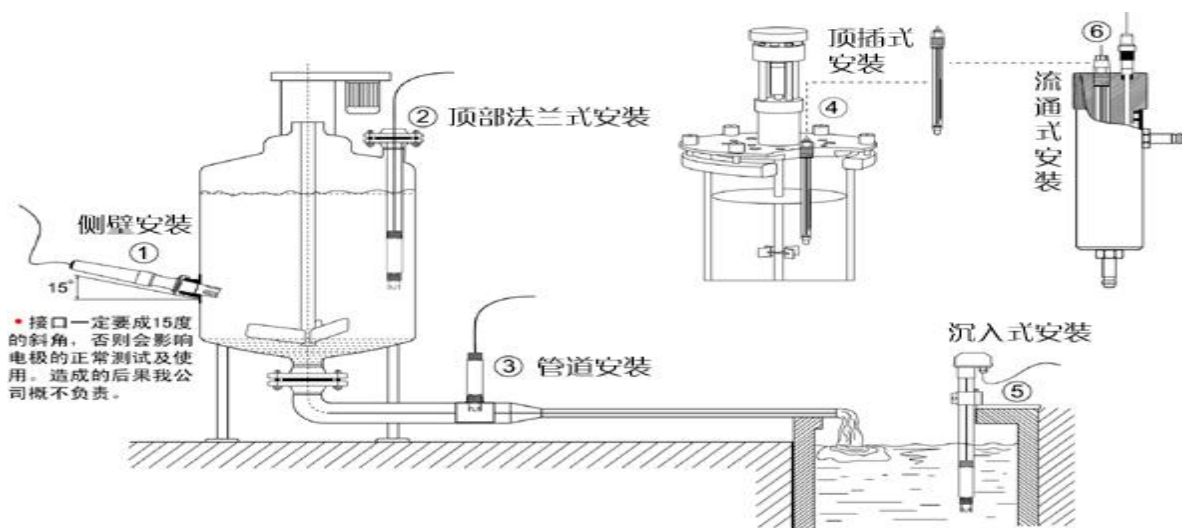

Note: The sensor should not be installed upside down or horizontally, but should be tilted at least 15 degrees.

### 2. Electrical connection

The cable is 5-core twisted pair shielded wire, the wire sequence definition:

- Red cord—power cord (12V~24VDC)
- Black cord —ground cord (GND)
- Blue cord—485A
- Green cord—485B
- Yellow cord—Current output (if unused, suspended)

The wiring sequence should be carefully checked before power-on to avoid unnecessary losses caused by faulty wiring.

**Wiring instructions:** Considering that cables are immersed in water (including sea water) or exposed to air for a long time, all cable connections must be waterproof. The cables must have the ability to prevent corrosion.

## IV.Maintenance

### 1. Use and maintenance

Electrodes should be soaked in tap water for 24 hours before testing and cleaned in deionized water after activation. If the electrode is not used for a long time (more than two weeks), it should be dried and stored. The inductive element of the electrode should be put into a protective cap.

Check whether the terminal is dry. If there is any stain, wipe it with anhydrous alcohol and blow dry before use. Long-term immersion in distilled water or protein solutions should be avoided, and contact with silicone grease should be prevented. Longer electrode use time, its PVC film may become translucent or attached to sediment, at this time can be distilled water (or deionized water) rinse. When the electrode is used for a long time and the measurement error occurs, it must be corrected.

If the electrode cannot be calibrated and measured during the maintenance and maintenance in the above way, it indicates that the electrode has failed. Please replace the electrode.

### 2. Sensor calibration

**Note: The sensor has been calibrated before delivery, and should not be calibrated at will unless the measurement error is exceeded.**

#### a) Zero point calibration

Put the sensor into the zero-point standard solution and wait for 10 minutes. After the value is stable, check whether the displayed value is within the error range. If not, zero-point calibration is required. Refer to Appendix for calibration instructions.

#### b) Slope calibration

Put the sensor into the slope standard solution and wait for 10 minutes. After the value is stable, check whether the displayed value is within the error range. If not, slope calibration is required. Refer to Appendix for calibration instructions.

## V.Quality and service

### 1. Quality assurance

- The quality inspection department has standardized inspection procedures, advanced and perfect testing equipment and means, and strictly in accordance with the regulations, to do a 72-hour aging test and stability test on the product, and not to allow one unqualified product to leave the factory.
- The receiving party directly returns the product batch with a failure rate of 2%, and all the costs incurred are borne by the supplier. The reference standard refers to the product description

---

provided by the supplier.

- Guarantee the quantity of goods and the speed of shipment.

## 2. Accessories spare and parts

This product includes:

- 1 sensor
- 1 copy of the manual
- 1 certificate
- 1 Cable (5 m)
- 10 mg/L and 100 mg/L calibration fluid each 100 ml or 100 mg/L and 1000 mg/L calibration fluid each 100 ml (according to the range and decide)

## 3. After-sales service commitment

The company provides local after-sales service within one year from the date of sale, but does not include damage caused by improper use. If repair or adjustment is required, please return it, but the shipping cost must be conceited. If damaged on the way, the company will repair the damage of the instrument for free.

## Appendix data communication

### 1. Data format

The default data format for Modbus communication is: 9600, n, 8, 1 (baud rate 9600bps, 1 start bit, 8 data bits, no parity, 1 stop bit).

Parameters such as baud rate can be customized.

#### 1. Format of information frames

##### a) Read data instruction frame

11	03	xx xx	xx xx	xx xx
address	Function code	Register address	Number of registers	CRC verification
code (low byte first)				

##### b) Read data response

11	03	xx	xx.....xx	xx xx
address	Function code	Number of bytes	Response data	CRC verification
code (low byte first)				

##### c) Write data instruction frame

11	06	xx xx	xx xx	xx xx
address	Function code	Register address	Write data	CRC verification code
(low byte first)				

##### d) Write data reply frame (same as write data instruction frame)

11	06	xx xx	xx xx	xx xx
address	Function code	Register address	Write data	CRC verification code
(low byte first)				

#### 2. Register address

Register Address	Name	Instructions	Number of Registers	Access Method
40001 (0x0000)	Total hardness measurement + temperature	Four double-byte integers, which are the total hardness measurement, measured decimal number, temperature value, and temperature value decimal number.	4 (8byte)	read
44097 (0x1000)	Zero point calibration	Calibration in 10mg/L or 100mg/L standard solution, 0 ~ 100mg/L written data is the value of the used standard solution concentration x100; 0	1 (2byte)	write/read

		~ 1000mg/L The written data is the value of the standard liquid concentration x10. The data read out is the mV value x100 corresponding to the zero calibration value.		
44101 (0x1004)	Calibration of slope	Calibration in 100mg/L or 1000mg/L standard solution, 0 ~ 100mg/L written data is the value of the used standard solution concentration x100; 0 ~ 1000mg/L The written data is the value of the standard liquid concentration x10. The data read is the mV value x100 corresponding to the slope calibration value.	1 (2byte)	write/read
44113 (0x1010)	Calibration of temperature	Calibration in solution, write data as the actual temperature value x10; The readout data is temperature calibration offset x10.	1 (2byte)	write/read
48195 (0x2002)	Address of sensor	The default value is 17, and the data range is 1 to 255.	1 (2byte)	write/read
48225 (0x2020)	Reset the sensor	The calibration value is restored to the default value and the data is written to 0. Note that the sensor needs to be calibrated again before it can be used.	1 (2byte)	write

### 3. Command examples

a) Read data instructions:

Function: Get the total hardness and temperature measured by the sensor; the unit of total hardness is mg/L (calculated as CaCO<sub>3</sub>); the unit of temperature is °C.

Request frame: 11 03 00 00 00 04 46 99

Response frame: 11 03 08 00 55 00 02 01 18 00 01 FD E9

Reading example:

Total hardness value	Temperature value
00 55 00 02	01 18 00 01

For example: total hardness value: 00 55 represents the total hardness value in hexadecimal reading, 00 02 represents the total hardness value with two decimal places, and the converted decimal value is 0.85.

Temperature value: 01 18 represents the hexadecimal reading temperature value, 00 01 represents the temperature value with one decimal place, and the converted decimal value is 28.0.

b) Calibration instructions:

Zero point calibration

Function: Set the total hardness zero point calibration value of the sensor. Calibrate in 100mg/L standard solution, the example is as follows:

Request frame: 11 06 10 00 03 E8 8F 24

Response frame: 11 06 10 00 03 E8 8F 24

slope calibration

Function: Set the total hardness slope calibration value of the sensor. Calibrate in 1000mg/L standard solution, the example is as follows:

Request frame: 11 06 10 04 27 10 D4 67

Response frame: 11 06 10 04 27 10 D4 67

c) Set device ID address

Function: Set the Modbus device address of the sensor.

Change the sensor address 11 to 01, the example is as follows

Request frame: 11 06 20 02 00 01 E0 9A

Response frame: 11 06 20 02 00 01 E0 9A

#### 4. Error response

If the sensor fails to execute the command of the upper computer correctly, the sensor will return the following message:

define	address	Function code	CODE	CRC verification
data	ADDR	COM+80H	xx	CRC 16
Number of bytes	1	1	1	2

a) CODE: 01 – Function code error  
03 – Wrong data

b) COM: Received function code