

NBL-WQ-KA-4A Online Potassium Ion Sensor User Manual



Changsha Zoko Link Technology Co., Ltd.

Tel:+8615367865107

E-mail: sales@niubol.com

Website: www.niubol.com

Address: Room 102, District D, Houhu Industrial Park, Yuelu District, Changsha City,

Hunan Province, China

User Notes

- Please read this manual carefully before use and save it for reference.
- Please follow the operating procedures and precautions in this manual.
- When receiving the instrument, please carefully open the package and check whether the instrument and accessories are damaged due to shipping. If any damage is found, please inform the manufacturer and distributor immediately, and keep the package for return.
- When the instrument fails, do not repair it yourself. Please contact the maintenance department of the manufacturer directly.

Content

User Notes	1
I. Application environment description	4
II. Technical performance and specifications	4
1. Technical parameters	4
2. Dimensional drawing	5
III. Installation and electrical connection	5
1. Installation	5
2. Electrical connection	6
IV. Maintenance and maintenance	6
1. Use and maintenance	6
2. Calibration of sensors	6
V. Quality and service	7
1. Quality assurance	7
2. Accessories and spare parts	7
3. After-sales service commitment	7
Appendix Data Communications	8

I. Application environment description

NBL-WQ-KA-4A integrated online potassium ion sensor is made of potassium ion selective electrode based on PVC membrane. It is used to test potassium ions in water. It is equipped with temperature compensation to ensure that the test is fast, simple, accurate and economical. This user manual details the technical parameters, use, maintenance and communication protocols of the potassium ion sensor.

- Signal output: RS-485 bus, Modbus/RTU protocol, easy to connect to third-party equipment such as PLC, DCS, industrial control computer, general controller, paperless recording instrument or touch screen.
- Patented potassium ion electrode, the internal reference liquid seeps out from the microporous salt bridge extremely slowly under a pressure of at least 100KPa (1Bar). Such a reference system is very stable and the electrode life is longer than that of ordinary industrial electrodes.
- Easy to install: 3/4NPT pipe thread, easy to sink in or install in pipes and tanks.
- IP68 protection level.

II. Technical performance and specifications

1. Technical parameters

Model	NBL-WQ-KA-4A	
Measuring range and resolution	0~100.00mg/L	0.01mg/L
	0~1000.0mg/L	0.1mg/L
	±10%F.S. of reading, ±0.5°C	
Accuracy	<90s	
Response time (T90) lowest detection limit	0.09 (0-100mg/L)	
	0.9 (0-1000mg/L)	
	-5~40°C	
storage temperature	0~40°C, <0.1MPa	
working conditions	4~10pH	
pH range of the medium	Automatic temperature compensation (Pt1000)	
Temperature compensation	12~24VDC	
powered by	RS-485(Modbus/RTU), 4-20mA (optional)	

Signal output	POM and 316L stainless steel
shell material	3/4NPT pipe thread, submersible installation
Installation method	5 meters, other lengths can be customized
Cable length	Two point calibration
Calibration method	0.2W@12V
Power consumption	IP68

2. Dimensional drawing

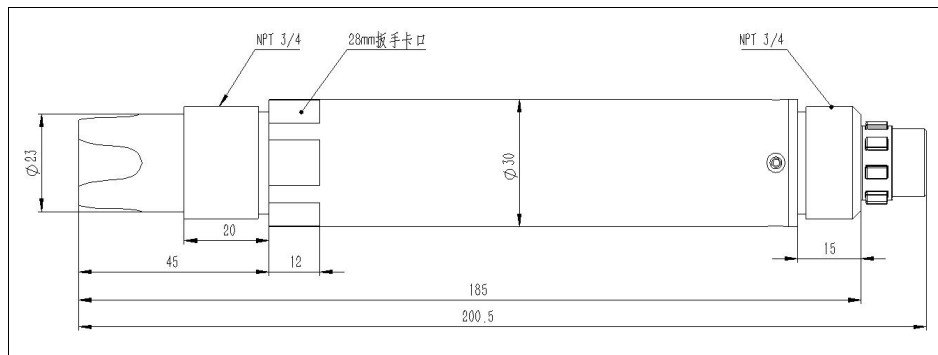

Note: The sensor connector is M16-5 core waterproof connector male

III. Installation and electrical connection

1. Installation

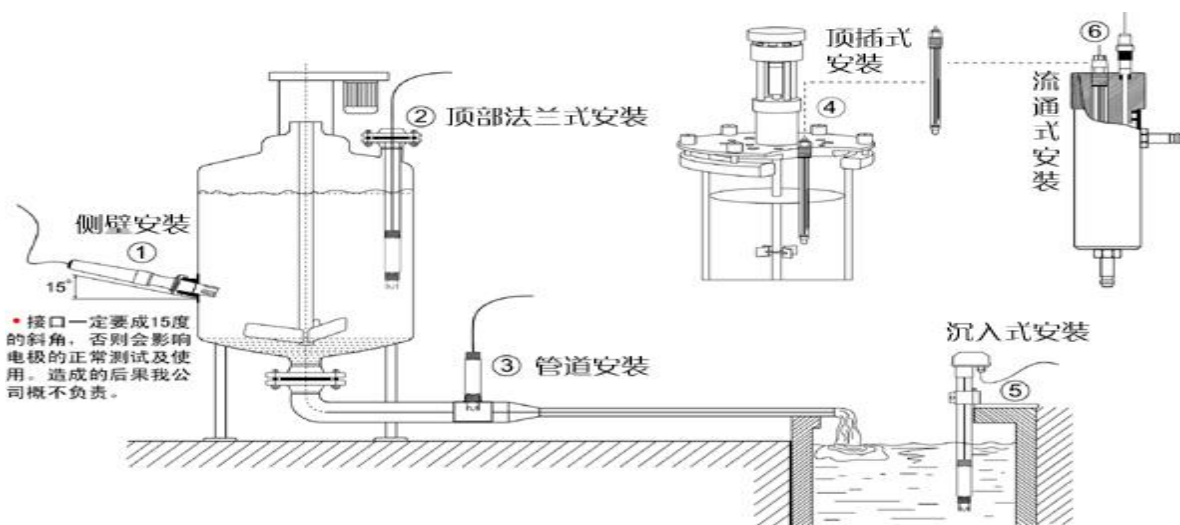

Note: The sensor cannot be installed upside down or horizontally, and must be installed at an angle of at least 15 degrees.

2. Electrical connection

The cable is a 5-core twisted pair shielded wire, and the line sequence is defined as follows:

- Red wire—power cord (12~24VDC)
- Black wire—ground wire (GND)
- Blue wire—485A
- Green line—485B
- Yellow wire—current output (if not used, it can be left floating)

The wiring sequence should be carefully checked before powering on to avoid unnecessary losses caused by wiring errors.

Wiring instructions: Considering that cables are immersed in water (including seawater) or exposed to the air for a long time, all wiring locations are required to be waterproofed, and user cables should have certain anti-corrosion capabilities.

IV. Maintenance and maintenance

1. Use and maintenance

Before testing, the electrode should be soaked in tap water for 24 hours. After activation is completed, it should be cleaned in deionized water. If the electrode is not used for a long period of time (more than two weeks), it must be stored dry, and the sensing element of the electrode should be placed in a protective cap.

Check whether the terminal block is dry. If there is any stain, please wipe it with absolute alcohol and blow dry before use. Long-term immersion in distilled water or protein solutions should be avoided, and contact with silicone grease should be avoided. If the electrode has been used for a long time, its PVC membrane may become translucent or have sediments attached. In this case, it can be rinsed with distilled water (or deionized water). When the electrode is used for a long time and measurement errors occur, correction must be performed.

If the electrode still cannot be calibrated and measured after maintaining it in the above manner, it means that the electrode has failed. Please replace the electrode.

2. Calibration of sensors

Note: The sensor has been calibrated before leaving the factory. It should not be calibrated at will unless the measurement error is exceeded.

a) Zero point calibration

Put the sensor into the zero point standard solution and wait for 10 minutes. After the value is stable, check whether the displayed value is within the error range. If not, zero point calibration is

required. Refer to the appendix for calibration instructions.

b) Slope calibration

Put the sensor into the slope standard solution and wait for 10 minutes. After the value is stable, check whether the displayed value is within the error range. If not, slope calibration is required. Refer to the appendix for calibration instructions.

V. Quality and service

1. Quality assurance

- The quality inspection department has standardized inspection procedures, advanced and complete testing equipment and means, and strictly follows the inspection procedures. It conducts 72-hour aging tests and stability tests on the products, and does not allow any unqualified products to leave the factory.

- The consignee will directly return batches of products with a defective rate of 2%, and all costs incurred will be borne by the supplier. For consideration criteria, refer to the product description provided by the supplier.

- Ensure supply quantity and shipping speed.

2. Accessories and spare parts

This product includes:

- 1 sensor
- 1 copy of instruction manual
- 1 certificate of conformity
- 100mL each of 10mg/L and 100mg/L calibration solutions or 100mL each of 100mg/L and 1000mg/L calibration solutions (depending on the range)

3. After-sales service commitment

Our company provides an after-sales guarantee for this machine within one year from the date of sale. The electrodes are consumables and have a half-year warranty. However, damage caused by improper use is not included. If repair or adjustment is required, please send it back, but the freight is at your own expense. When sending it back, make sure it is well packaged to avoid damage during transportation. Our company will repair the damage to the instrument free of charge.

Appendix Data Communications

1. Data format

The default data format of Modbus communication is: 9600, n, 8, 1 (baud rate 9600bps, 1 start bit, 8 data bits, no parity, 1 stop bit).

Parameters such as baud rate can be customized.

2. Information frame format

a) Read data instruction frame

44	03	xx xx	xx xx	xx xx
Address	Function code	Register Address	Number of registers	CRC check
code(low byte first)				

b) Read data response frame

44	03	xx	xx.....xx	xx xx
Address	Function code	Bytes	Answer data	CRC check code(low
byte first)				

c) Write data command frame

44	06	xx xx	xx xx	xx xx
Address	Function code	Register Address	Write data	CRC check code(low
byte first)				

d) Write data response frame (same as write data command frame)

44	06	xx xx	xx xx	xx xx
Address	Function code	Register Address	Write data	CRC check code(low
byte first)				

3. Register address

Register address	Name	Illustrate	Number of registers	interview method
40001 (0x0000)	Potassium ion measurement + temperature	4 double-byte integers, which are the measured value of potassium ions, the number of decimal places in the measured value, the temperature value, and the number of decimal places in the temperature value.	4 (8 bytes)	read
44097 (0x1000)	Zero point calibration	Calibrated in 10mg/L or 100mg/L standard solution, the written data for 0~100mg/L is the value of the	1 (2 bytes)	write/read

		concentration of the standard solution used x100; the written data for 0~1000mg/L is the value of the concentration of the standard solution x10 used. The read data is the mV value x100 corresponding to the zero point calibration value.		
44101 (0x1004)	slope calibration	Calibrated in 100mg/L or 1000mg/L standard solution, the written data for 0~100mg/L is the value of the concentration of the standard solution used x100; the written data for 0~1000mg/L is the value of the concentration of the standard solution x10 used. The data read out is the mV value x100 corresponding to the slope calibration value.	1 (2 bytes)	write/read
44113 (0x1010)	temperature calibration	Calibrated in solution, the written data is the actual temperature value x10; the read data is the temperature calibration offset x10.	1 (2 bytes)	write/read
48195 (0x2002)	sensor address	The default is 68, and the write data range is 1~255.	1 (2 bytes)	write/read
48225 (0x2020)	Reset sensor	The calibration value returns to the default value, and the written data is 0. Note that the sensor needs to be calibrated again after resetting before it can be used.	1 (2 bytes)	Write

4. Command examples

a) Read data instructions:

Function: Get the potassium ions and temperature measured by the sensor; the unit of potassium ions is mg/L; the unit of temperature is °C.

Request frame: 44 03 00 00 00 04 4A 9C

Response frame: 44 03 08 00 55 00 02 01 18 00 01 ED 24

Reading example:

Potassium ion value	temperature value
00 55 00 02	01 18 00 01

For example: Potassium ion value: 00 55 represents the potassium ion value in hexadecimal reading, 00 02 represents the potassium ion value with two decimal places, and the converted decimal value is 0.85.

Temperature value: 01 18 represents the hexadecimal reading temperature value, 00 01 represents the temperature value with one decimal place, and the converted decimal value is 28.0.

b) Calibration instructions:

Zero point calibration

Function: Set the potassium ion zero point calibration value of the sensor. Calibrate in 100mg/L standard solution, the example is as follows:

Request frame: 44 06 10 00 03 E8 83 21

Response frame: 44 06 10 00 03 E8 83 21

slope calibration

Function: Set the potassium ion slope calibration value of the sensor. Calibrate in 1000mg/L standard solution, the example is as follows:

Request frame: 44 06 10 04 27 10 D8 62

Response frame: 44 06 10 04 27 10 D8 62

c) Set device ID address

Function: Set the Modbus device address of the sensor.

Change the sensor address 44 to 01, the example is as follows

Request frame: 44 06 20 02 00 01 EC 9F

Response frame: 44 06 20 02 00 01 EC 9F

5. Error response

If the sensor cannot correctly execute the host computer command, it will return information in the following format:

Definition	Address	Function code	Code	CRC check
Data	ADDR	COM+80H	xx	CRC 16
Number of bytes	1	1	1	2

a) CODE: 01 –Function code error

03 – Data is wrong

b) COM: The received function code